

Australian Standard™

**Galvanic (sacrificial) anodes for
cathodic protection**

This Australian Standard was prepared by Committee MT-014, Corrosion of Metals. It was approved on behalf of the Council of Standards Australia on 24 September 2003 and published on 24 November 2003.

The following are represented on Committee MT-014:

- Australasian Corrosion Association
- Australasian Institute of Metal Finishing
- Australian Chamber of Commerce and Industry
- Australian Electrolysis Committee
- The Australian Gas Association
- Australian Paint Manufacturers' Federation
- Australian Paint Approval Scheme
- Austrroads
- Bureau of Steel Manufacturers of Australia
- Corrosion Prevention Centre
- Department of Defence
- Division of Building, Construction and Engineering, CSIRO
- Galvanizers Association of Australia
- Telstra
- United Water International
- Water Services Association of Australia

Additional interests participating in the preparation of this Standard:

- Corrosion consultants
- Department of Minerals and Energy
- Gas and Fuel Corporation of Victoria
- Hunter Water Board
- Petroleum refineries
- State Electricity Commission of Victoria
- Water Authority of Western Australia
- Water Resources Commission, Queensland

Keeping Standards up-to-date

Standards are living documents which reflect progress in science, technology and systems. To maintain their currency, all Standards are periodically reviewed, and new editions are published. Between editions, amendments may be issued. Standards may also be withdrawn. It is important that readers assure themselves they are using a current Standard, which should include any amendments which may have been published since the Standard was purchased.

Detailed information about Standards can be found by visiting the Standards Australia web site at www.standards.com.au and looking up the relevant Standard in the on-line catalogue.

Alternatively, the printed Catalogue provides information current at 1 January each year, and the monthly magazine, *The Global Standard*, has a full listing of revisions and amendments published each month.

We also welcome suggestions for improvement in our Standards, and especially encourage readers to notify us immediately of any apparent inaccuracies or ambiguities. Contact us via email at mail@standards.com.au, or write to the Chief Executive, Standards Australia International Ltd, GPO Box 5420, Sydney, NSW 2001.

This Standard was issued in draft form for comment as DR 03185.

Australian Standard™

**Galvanic (sacrificial) anodes for
cathodic protection**

Originated as AS 2239—1979.
Previous edition AS 2239—1993.
Third edition 2003.

COPYRIGHT

© Standards Australia International

All rights are reserved. No part of this work may be reproduced or copied in any form or by any means, electronic or mechanical, including photocopying, without the written permission of the publisher.

Published by Standards Australia International Ltd
GPO Box 5420, Sydney, NSW 2001, Australia

ISBN 0 7337 5574 7

PREFACE

The Standard was prepared by the Australian members of the Joint Standards Australia/Standards New Zealand Committee MT-014, Corrosion of Metals to supersede AS 2239—1993, *Galvanic (sacrificial) anodes for cathodic protection*. After consultation with stakeholders in both countries, Standards Australia and Standards New Zealand decided to develop this Standard as an Australian, rather than an Australian/New Zealand Standard.

The objective of this Standard is to specify the requirements for those common anode alloys available in Australia for use in cathodic protection systems, such as those specified in the AS 2832 series of Standards.

The objective of this revision is to include new specifications and chemical composition limits for anodes.

The terms ‘normative’ and ‘informative’ have been used in this Standard to define the application of the appendix to which they apply. A ‘normative’ appendix is an integral part of a Standard, whereas an ‘informative’ appendix is only for informative and guidance.

.

CONTENTS

	<i>Page</i>
SECTION 1 SCOPE AND GENERAL	
1.1 SCOPE.....	4
1.2 REFERENCED DOCUMENTS.....	4
1.3 DEFINITIONS.....	4
1.4 DESIGNATION	6
1.5 FREEDOM FROM DEFECTS	7
1.6 MARKING	7
1.7 ROUNDING OF TEST RESULT VALUES.....	7
SECTION 2 ANODE AND CORE REQUIREMENTS	
2.1 SCOPE OF SECTION	8
2.2 ANODES	8
2.3 CORES	8
SECTION 3 PERFORMANCE REQUIREMENTS	
3.1 SCOPE OF SECTION	15
3.2 MECHANICAL TEST.....	15
3.3 ELECTRICAL RESISTANCE.....	15
3.4 CONSUMPTION RATE OF ALUMINIUM ANODES IN SEA WATER.....	15
3.5 CLOSED CIRCUIT POTENTIAL OF ALUMINIUM ANODES IN SEA WATER..	15
SECTION 4 BACKFILL FOR BURIED MAGNESIUM AND ZINC GALVANIC ANODES	
4.1 GENERAL.....	16
4.2 BACKFILL COMPOSITION	16
4.3 PROPERTIES AND APPLICATION	17
4.4 PACKAGED ANODES	17
APPENDICES	
A PURCHASING GUIDELINES.....	18
B GUIDANCE ON THE APPLICATION OF ANODES	19
C METHOD FOR THE DETERMINATION OF THE ANODE-TO-CORE RESISTANCE OF GALVANIC ANODES	28
D METHOD FOR THE DETERMINATION OF THE CONSUMPTION RATE OF ALUMINIUM ANODE ALLOYS IMMERSSED IN SEA WATER	31
E METHOD FOR THE DETERMINATION OF THE CLOSED-CIRCUIT POTENTIAL OF ALUMINIUM ANODES IMMERSSED IN SEA WATER	34

STANDARDS AUSTRALIA

Australian Standard**Galvanic (sacrificial) anodes for cathodic protection**

SECTION 1 SCOPE AND GENERAL

1.1 SCOPE

This Standard specifies requirements for galvanic (sacrificial) anodes for use in the cathodic protection of metals against corrosion. It specifies the composition of suitable alloys for magnesium, zinc and aluminium anodes and gives details of shapes and design features of some commonly used anodes. It also includes details of backfill compositions and properties, for buried magnesium and zinc anodes.

NOTE: Advice and recommendations on information to be supplied by the purchaser at the time of enquiry or order are contained in the purchasing guidelines set out in Appendix A.

1.2 REFERENCED DOCUMENTS

The following documents are referred to in this Standard:

AS

1042 Direct-acting indicating electrical measuring instruments and their accessories

1152 Specification for test sieves

1627 Metal finishing—Preparation and pretreatment of surfaces

1627.9 Part 9: Pictorial surface preparation standards for painting steel surfaces

2706 Numerical values—Rounding and interpretation of limiting values

2832 Cathodic protection of metals

2832.4 Part 4: Internal surfaces

AS/NZS

1125 Conductors in insulated electric cables and flexible cords

3008 Electrical installations—Selection of cables

3008.1.1 Part 1.1: Cables for alternating voltages up to and including 0.6/1 kV—Typical Australian installation conditions

ASTM

D1141 Standard practice for the preparation of substitute ocean water

MIL-A

18001k Anodes, corrosion preventive, zinc; slab disc and rod shaped

1.3 DEFINITIONS

For the purpose of this Standard, the definitions below apply.

1.3.1 Anode (in general)

An electrode, placed in the electrolyte, to apply cathodic protection to the structure.

1.3.2 Anode backfill

Material surrounding and in contact with a buried anode to maintain or improve its performance.

1.3.3 Anode consumption rate

The rate of alloy mass consumption for a given current output over a given period; normally stated in kilograms per ampere year.

1.3.4 Anode core

A metal insert (usually steel) either cast into the anode or extruded with the anode to provide mechanical strength and attachment.

1.3.5 Cathode

The structure that is to be protected by cathodic protection.

1.3.6 Cathodic protection

The prevention or reduction of corrosion of metal by making the metal the cathode in a galvanic or electrolytic cell.

1.3.7 Closed circuit potential

The potential of an anode connected to a structure when passing current; normally measured against a reference electrode in a particular environment.

1.3.8 Copper/copper sulfate (Cu/CuSO₄) reference electrode

A reference electrode consisting of copper in a saturated solution of copper sulfate.

1.3.9 Current capacity

The total current flow available from an anode of given mass of alloy; normally expressed as ampere years per kilogram. This is the inverse of the anode consumption rate.

1.3.10 Current density (at anode)

Current output of anode divided by the anode surface area.

1.3.11 Current density (at cathode)

Current flowing into cathode divided by the cathode surface area.

1.3.12 Current density (at coated cathode)

Total current flow into cathode divided by the total surface area of the structure.

1.3.13 Driving potential

The difference between the open circuit potentials of the anode and the structure.

1.3.14 Electrolyte

A liquid, or the liquid component in a composite material such as soil, in which electric current may flow by ionic charge transfer.

1.3.15 Galvanic action

A spontaneous electrochemical cell reaction in which a metallic anode in a dissimilar metal couple corrodes.

1.3.16 Galvanic anode

An electrode used to protect a structure by galvanic action.

1.3.17 Gross anode mass

Total mass of an un-packaged anode, including core, cable and connection.

1.3.18 Gross anode packaged weight

Total mass of a packaged anode, including core, cable, connection and backfill.

1.3.19 Net anode mass

Mass of actual anode alloy.

1.3.20 Open circuit potential

The potential of an anode when not connected to a structure; normally measured against a reference electrode in a particular environment.

1.3.21 Packaged anode

Either a magnesium or zinc anode placed, with backfill, in a calico bag or other approved container to provide a uniform low resistivity environment for the anode.

1.3.22 Reference electrode

An electrode which has a stable potential in one or more electrolytes at a given temperature, thus enabling it to be used for the measurement of other electrode potentials.

1.3.23 Resistivity

Resistance per unit length through a unit area cross-section, (ohm.m).

1.3.24 Silver/silver chloride reference electrode (Ag/AgCl)

An electrode consisting of silver, coated with silver chloride, in an electrolyte containing chloride ions.

1.3.25 Test anode

A prepared anode test piece, made from a test specimen by a mechanical operation.

1.3.26 Test sample

A portion of material or a group of items selected from a batch or consignment by a sampling procedure.

1.3.27 Test specimen

A portion of material or a single item taken from the test sample for the purpose of applying a particular test.

1.4 DESIGNATION**1.4.1 Anodes**

The anode designation shall consist of the following components:

- (a) A prefix number or numbers indicating the net alloy mass.
- (b) A letter indicating the alloy material as follows:
 - (i) A..... aluminium.
 - (ii) M..... magnesium.
 - (iii) Z..... zinc.
- (c) The series number of the alloy.

Example of designation: 10Z1 indicates a 10 kg anode of alloy Z1, the first alloy in the series.

1.4.2 Backfill

Backfill surrounds for anodes shall be designated in accordance with their composition, as follows:

- (a) B1 calcium bentonite/gypsum.
- (b) B2 sodium bentonite/gypsum.
- (c) B3 as for Items (a) or (b) with additions of sodium sulfate.

1.5 FREEDOM FROM DEFECTS

Anodes shall be produced from primary metal alloys. No secondary metal or scrap shall be used, with the exception of house generated scrap from rejected anodes during the forming process.

Defects shall not affect the performance or function of the anodes in service. Anodes shall be free of inclusions or defects which could cause the loss of electrical contact, the flaking of surface metal or any other adverse effects.

NOTE: Defects such as inclusions, segregation or surface flaws cannot be completely quantified. Where the presence, size or frequency of any of these are considered to be of concern, arrangements should be made between the purchaser/regulatory authority/certifying body (as appropriate), and the manufacturer. This may be achieved by the provision of acceptable type samples or methods of test.

Where defects are present and the product is submitted for acceptance, the manufacturer should be able to demonstrate fitness for use.

1.6 MARKING

The following information shall be legibly and durably marked on each anode or group of anodes supplied, or on a label securely fixed to each anode, unless otherwise requested by the customer:

- (a) The name or registered mark of the manufacturer or supplier.
- (b) The alloy designation.
- (c) Nominal net mass of the anode and, in the case of a packaged anode, the gross anode package weight.
NOTE: Gross mass also includes the mass of the cable attached to the anode.
- (d) If appropriate, the instruction 'remove plastic bag prior to installation of the anode'.
- (e) The backfill composition.

NOTE: Manufacturers making a statement of compliance with this Australian Standard on a product, packaging, or promotional material related to that product, are advised to ensure that such compliance is capable of being verified.

1.7 ROUNDING OF TEST RESULT VALUES

For the purpose of assessing compliance with this Standard, the specified limiting values herein shall be interpreted in accordance with the rounding method described in AS 2706, i.e. the observed or calculated value shall be rounded to the same number of figures as in the specified limiting value and then compared with the specified limiting value.

SECTION 2 ANODE AND CORE REQUIREMENTS

2.1 SCOPE OF SECTION

This Section specifies requirements for anodes, cores, core cables and cable attachment, describes the type and shapes of magnesium, zinc and aluminium anodes, and provides guidelines on how they should be selected and applied for cathodic protection.

2.2 ANODES

2.2.1 Anode composition

The chemical composition of the anode shall comply with the limits given in Tables 2.1, 2.2 and 2.3, as appropriate.

2.2.2 Anode mass and dimensions

Galvanic anodes are available in a variety of forms and masses.

NOTE: Appendix B describes typical anode forms and lists the masses and nominal dimensions.

2.3 CORES

2.3.1 Placement of anode core

For cast anodes, the core cover shall not be less than 10 mm thick. The exception being rod anodes where the core is placed centrally.

Unless otherwise specified, the anode shall be designed with the core located centrally, within 10% of the axis, within the surrounding anodic material to enable the anode to corrode as evenly as possible around the core. The position of the anode core shall be such that the maximum possible mass of anode material is available to provide cathodic protection.

NOTE: Information on core sizes is given in Appendix B.

2.3.2 Materials and finish

Requirements need to be discussed between the purchaser and manufacturer in regards to the required finish of anode core materials.

Cores shall be abraded or otherwise treated to ensure that the requirements of Clauses 3.2, 3.3 and 3.4 shall be achieved. All insert material shall be free from rust, mill scale, oil and any other contaminants.

The following materials and finishes are used for the manufacture of cores:

- (a) Extruded magnesium—steel wire cold drawn.
- (b) Cast magnesium—steel rod or flats either clean mill finish or abrasive blasted to Class 2, Class 2.5 or Class 3 as specified by AS 1627.9.

Zinc coatings shall not be used on steel core of magnesium alloy anodes.

- (c) Extruded or cast zinc—zinc coated steel wire, mill finish steel rod or flats. Abrasive blasted mill finish steel rod or flats. Electroplated zinc coated steel and hot dip galvanized steel.

NOTE: Aluminium inserted cores may be used for cast zinc anodes where the anode is used to protect aluminium.

- (d) Extruded aluminium—steel wire, cold drawn.
- (e) Cast aluminium—Steel rod flats either clean mill finish or abrasive blasted to Class 2, 2½ or Class 3 as specified by AS 1627.9.

Zinc coatings shall not be used on the steel core of aluminium alloy anodes.

2.3.3 Bonding of core to anode

Cores shall be thoroughly dried prior to manufacture of the anode. For blast cleaned steel cores, casting shall proceed within 48 hours of blast cleaning. If any visible signs of flash rusting appear by the time casting is to commence, the steel cores shall be re-cleaned.

Wire used as core material shall be free of grease and oil, which, if present, can cause bubbling in the anode material and lack of bond between the core and the anode.

2.3.4 Methods of attachment of cable for buried anodes

For buried anodes, a length of 7/1.04 insulated copper cable conforming to AS/NZS 3008.1.1, or other appropriately insulated copper cable, shall be attached to the anode core by an appropriate method. The method of attachment shall provide compliances with the mechanical requirements specified in Clause 3.2. Typical methods of attachment are as follows:

- (a) *For magnesium anodes* For magnesium anodes, typical methods of attachment are shown in Figures 2.1, 2.2, 2.3 and 2.4. After attachment, a mastic/adhesive-lined polyethylene heat-shrink sleeve is applied to protect the joint mechanically. A crimped connection may be encapsulated with epoxy resin for this purpose.
- (b) *For anodes other than magnesium* A typical method of attachment are shown in Figures 2.2, 2.3 and 2.4. After attachment, a mastic/adhesive-lined polyethylene heat-shrink sleeve is applied to protect the joint mechanically. A crimped connection may be encapsulated with epoxy resin for this purpose.

NOTES:

- 1 Anodes exceeding 25 kg in nett weight should be suspended by means other than by the connection cable.
- 2 Methods of attachment of cables for anodes suspended in water require special designs and are outside the scope of this Standard. Guidelines for cable attachment in tanks and reservoirs are provided in AS 2832.4.

2.3.5 Colour of cable insulation

The colour of the insulation of anode cables shall be red, unless otherwise specified by the purchaser.

TABLE 2.1
CHEMICAL COMPOSITION LIMITS FOR MAGNESIUM ALLOY ANODES

Element	Chemical composition, %					
	Cast or extruded high potential		Extruded low potential		Cast low potential	
	Designation M1		Designation M2		Designation M3	
	Min.	Max.	Min.	Max.	Min.	Max.
Aluminium	—	0.01	2.5	3.5	5.3	6.7
Zinc	—	0.02	0.7	1.3	2.5	3.5
Manganese	0.50	1.3*	0.20	1.5	0.25	0.40
Silicon	—	0.05	—	0.05	—	0.05
Copper	—	0.02	—	0.006	—	0.05
Iron	—	0.03	—	0.003	—	0.03
Nickel	—	0.001	—	0.001	—	0.003
Calcium	—	0.04	—	0.04	—	0.04
Other impurities						
— each	—	0.05	—	—	—	—
— total	—	0.30	—	0.30	—	0.30
Magnesium	remainder		remainder		remainder	

* In the range 0.50 to 0.80%, the percentage of manganese is required to be at least $0.5 + (60 \times \% \text{ aluminium})$.

NOTES:

- 1 Alloy M1 is a high potential anode material and is used in high resistivity soils and waters.
- 2 Alloys M2 and M3 are low potential anode materials and are used in medium resistivity soils and water. Alloy M2 is also used in hot-water applications for temperatures up to 85°C.
- 3 In order to minimize self-corrosion of alloy M2 when used in domestic water storage heater applications, it has been found desirable to maintain the iron content below 0.003%, with 0.20-0.6% manganese.
- 4 Magnesium anodes are not suitable for long term protection in sea water.

TABLE 2.2
CHEMICAL COMPOSITION LIMITS FOR ZINC ALLOY ANODES

Element	Chemical composition, %			
	Z1* Min.	Z1* Max.	Z2 Min.	Z2 Max.
Cadmium	0.025	0.07	—	0.003
Aluminium	0.10	0.50	—	0.005
Silicon	—	0.005	—	0.003
Copper	—	0.005	—	0.003
Iron	—	0.005	—	0.0014
Lead	—	0.006	—	0.003
Other impurities				
—each	—	0.005	—	0.005
—total	—	0.02	—	0.02
Zinc	remainder		remainder	

* Corresponds to MIL-A-18001k alloy composition.

NOTE: Typical uses for these alloys are given in Paragraph B3.2.

TABLE 2.3
CHEMICAL COMPOSITION LIMITS FOR ALUMINIUM ALLOY ANODES

Element	Chemical composition, %							
	Designation A1		Designation A2		Designation A5		Designation A6	
	Min.	Max.	Min.	Max.	Min.	Max.	Min.	Max.
Zinc	2.1	2.7	3.0	5.0	4.0	5.0	2.0	6.0
Indium	0.017	0.025	0.02	0.05	—	—	0.01	0.02
Cadmium	0.008	0.012	—	0.005	—	0.005	—	0.005
Silicon	—	0.20	—	0.20	—	0.25	0.08	0.12
Iron	—	0.12	—	0.12	—	0.25	—	0.12
Magnesium	—	—	0.6	2.2	—	—	—	0.02
Titanium	—	—	0.02	0.05	—	—	—	0.02
Copper	—	0.006	—	0.006	—	—	—	0.006
Tin	—	—	—	—	0.05	0.25	—	0.02
Other impurities								
—each	—	0.02	—	0.02	—	—	—	0.02
—total	—	0.05	—	0.05	—	0.15	—	0.05
Aluminium	remainder		remainder		remainder		remainder	

NOTES:

- 1 Alloys A1, A2 and A6 are commonly used in Australia for sea water applications.
- 2 Alloy A5 is used in potable water systems for temperatures up to 85°C.
- 3 Aluminium alloys activated against self passivation by toxic elements such as Indium, Thallium, Cadmium, or Mercury are unacceptable for use in domestic water storage heater applications.

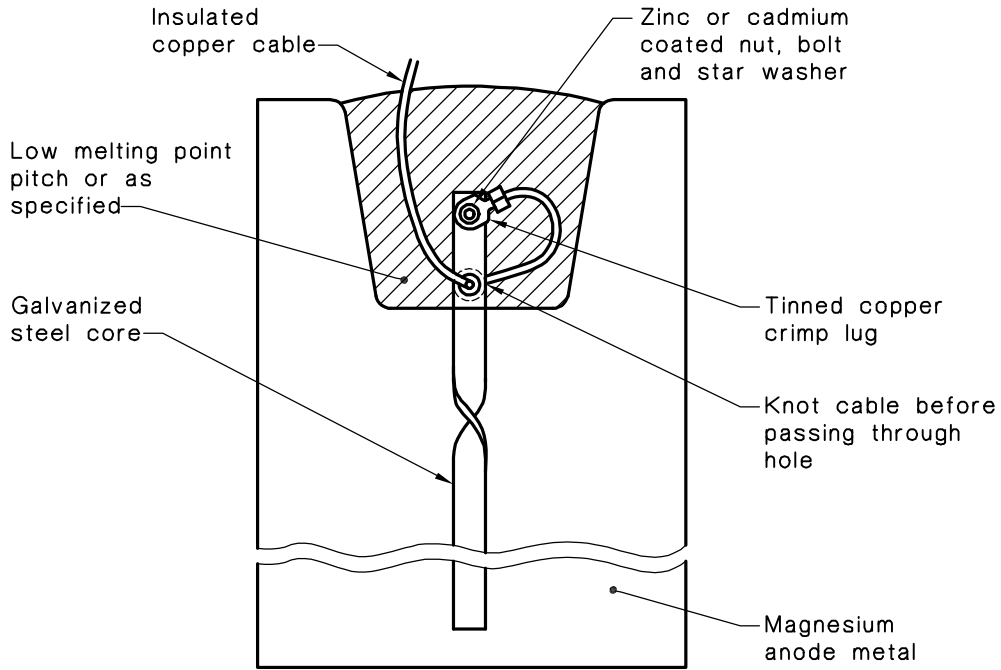
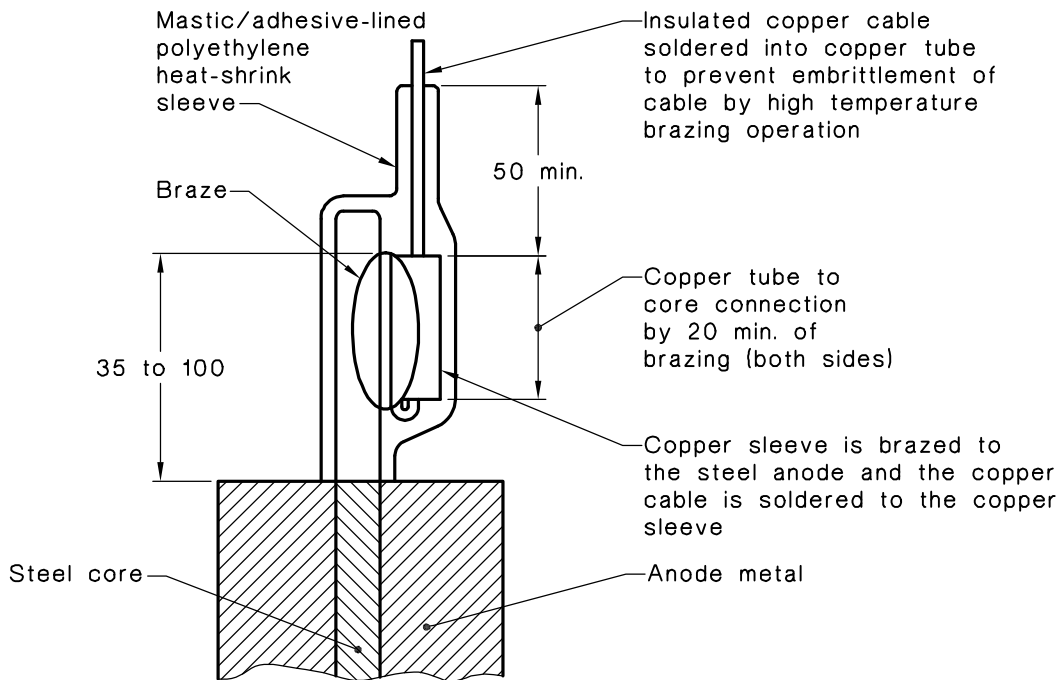

FIGURE 2.1 METHOD OF CABLE ATTACHMENT FOR BURIED MAGNESIUM ANODES



DIMENSIONS IN MILLIMETRES

FIGURE 2.2 METHOD OF CABLE ATTACHMENT FOR BURIED ANODES

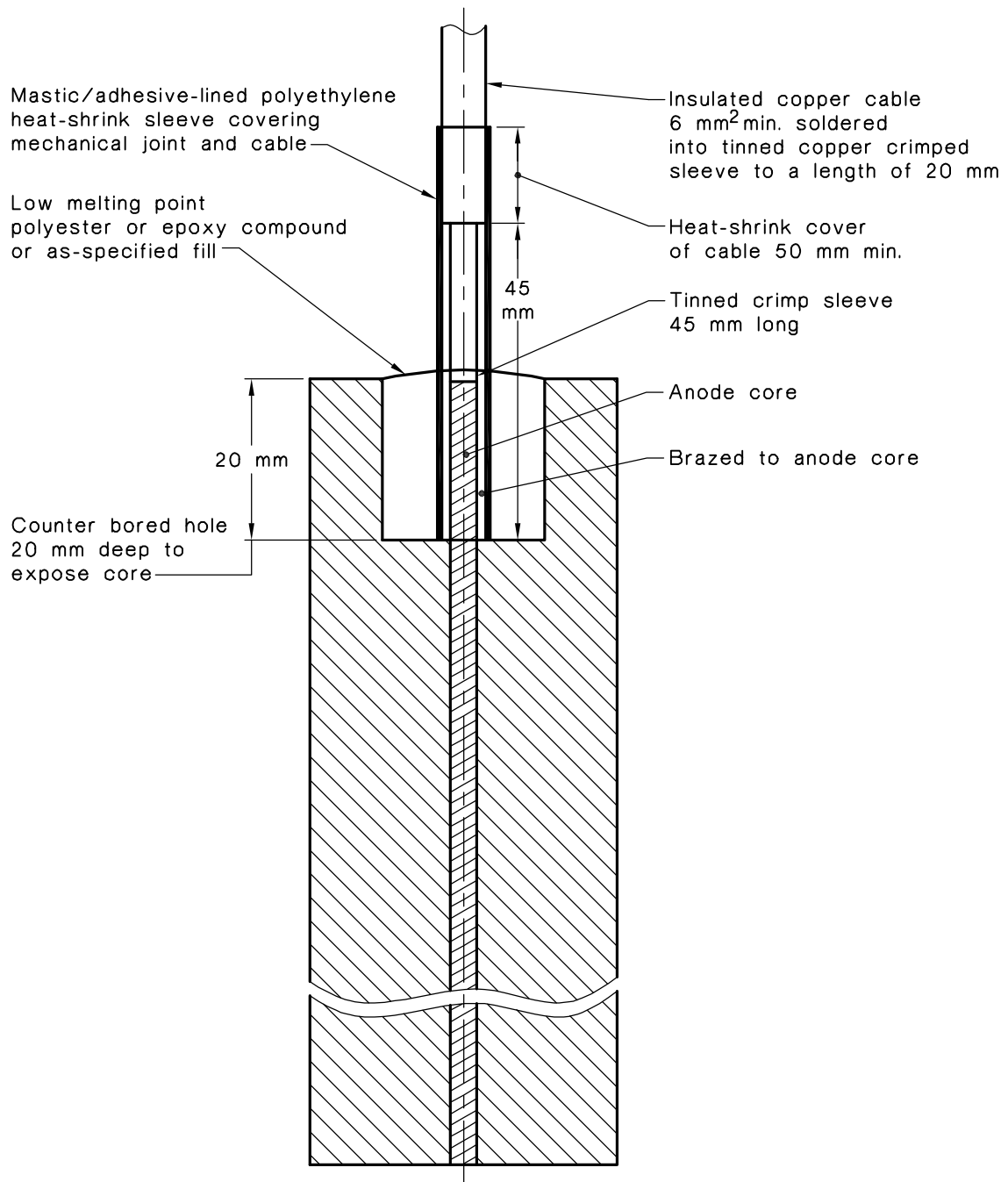

FIGURE 2.3 METHOD OF CABLE ATTACHMENT FOR EXTRUDED BURIED MAGNESIUM ANODES

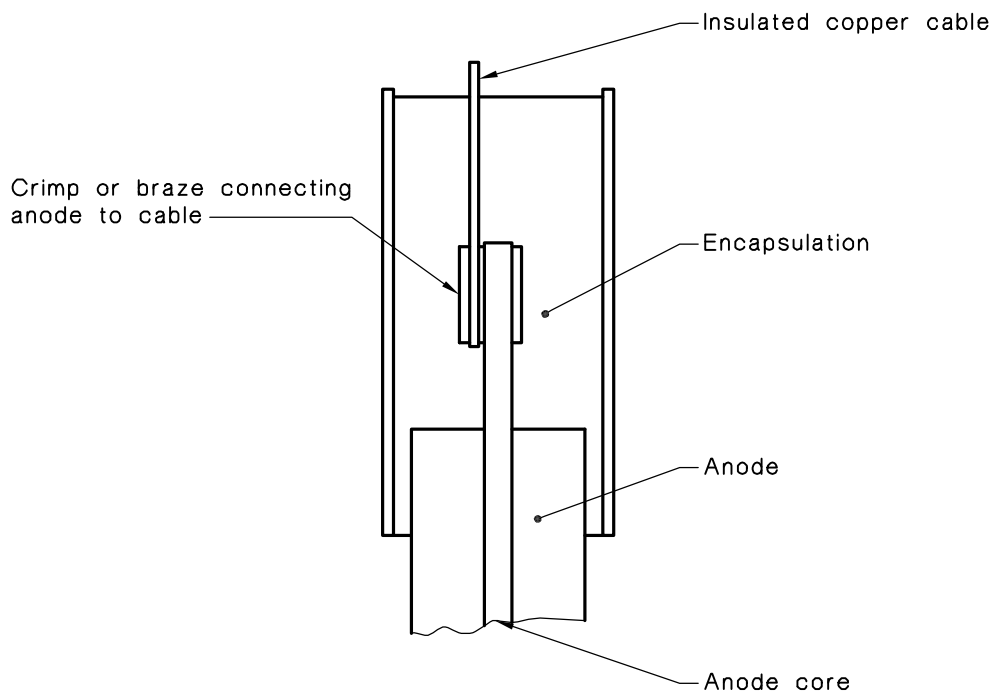

FIGURE 2.4 METHOD OF CABLE ATTACHMENT USING CRIMPING OR BRAZING

SECTION 3 PERFORMANCE REQUIREMENTS

3.1 SCOPE OF SECTION

This Section specifies the mechanical, electrical, cable joint strength and consumption rate requirements for aluminium, magnesium and zinc galvanic anodes, and the close-circuit potential requirements for aluminium anodes in seawater.

3.2 MECHANICAL TEST

When a uniaxial force equivalent to 100 kg, or five times the mass of the anode metal, whichever is the greater, is applied to an anode containing a core, no movement of the core or any metal insert shall occur. Where a cable is provided, a uniaxial loading of 100 kg shall not result in damage to the cable or its connections.

3.3 ELECTRICAL RESISTANCE

When determined in accordance with the test method in Appendix C, the electrical resistance of the anode to core or, if appropriate, of the anode to the near end of the cable, shall be not greater than 0.01Ω for the life of the anode.

3.4 CONSUMPTION RATE OF ALUMINIUM ANODES IN SEA WATER

When determined in accordance with the test method in Appendix D, the typical consumption rate of an aluminium anode in sea water is 3.5 kg/A.year.

NOTE: The test specified in Appendix D is applicable to aluminium anodes only. Typical consumption rates for magnesium anodes in soil or zinc anodes in soil or sea water are given in Table B1 of Appendix B.

3.5 CLOSED CIRCUIT POTENTIAL OF ALUMINIUM ANODES IN SEA WATER

When determined in accordance with Appendix E, the closed-circuit potential of an aluminium anode shall be at least -1.05 V with respect to a silver/silver chloride/sea water reference electrode.

NOTE: The test specified in Appendix E is relevant for aluminium anodes only.

SECTION 4 BACKFILL FOR BURIED
MAGNESIUM AND ZINC GALVANIC ANODES

4.1 GENERAL

Backfills are placed around anodes for the following reasons:

- (a) To provide a uniform environment around the anode to allow it to corrode uniformly and to allow continuous effective operation.
- (b) To lower the resistance of the anode to the surrounding soil and to improve electrical conductivity.
- (c) To maintain a moist environment.

Carbonaceous backfills shall not be used with galvanic anodes.

The most commonly used backfills are mixtures of—

- (i) a suitable clay, to retain moisture; and
 NOTE: Sodium and calcium bentonite and, to a lesser extent, kaolinite are suitable clays for use as backfill. The physical properties of these clays, such as wet swelling, dry shrinkage, electrical conductivity and water retention, vary widely.
- (ii) agricultural gypsum, to improve their physical properties and electrical conductivity.

Gypsum is added to modify the properties of the clays. To have effective wetting and handling properties, the particle size of the gypsum shall be graded, (refer to AS 1152). The particle size distribution for gypsum and bentonites shall meet the specifications in Table 4.1.

**TABLE 4.1
PARTICLE SIZE DISTRIBUTION FOR
GYPSUM AND BENTONITES**

Sieve mesh size µm	Distribution, % pass
1000	100
600	90
150	70
45	30

NOTE: A back fill mixture should be graded and not all fines, to facilitate the wetting of the backfill.

4.2 BACKFILL COMPOSITION

Backfill surrounds for magnesium and zinc anodes shall be designated in accordance with Clause 1.4.2. They typically consist of one of following nominal compositions:

- (a) *Designation B1*
 - (i) Calcium bentonite 50% by mass.
 - (ii) Gypsum 50% by mass.

- (b) *Designation B2*
- (i) Sodium bentonite 60% by mass.
- (ii) Gypsum 40% by mass.
- (c) *Designation B3*

Having similar composition to B1 with additional sodium sulfate (typically 5%).

NOTES:

- 1 Backfill designation B1 is for general usage.
- 2 Backfill designation B2 is recommended for use where there is a permanent water table.
- 3 Backfill designation B3 is recommended for use where improved water permeability at the installation is required. The as-installed resistance to ground is likely to be lower than the final working value. Sodium sulfate and other conducting materials should not be used where there is a permanent water table, because of their tendency to leach.

4.3 PROPERTIES AND APPLICATION

After anode installation, backfills shall be well compacted around the anode and dampened down, when necessary, by liberal application of water, before completing the total backfilling of the excavation. The significant differences between the properties of the backfill compositions listed in Clause 4.2 are given in Table 4.2.

TABLE 4.2
TYPICAL PROPERTIES OF BACKFILL COMPOSITIONS

Property	Designation B1* (calcium bentonite and gypsum)	Designation B2 (sodium bentonite and gypsum)
Degree of swelling when wet	Very little swelling (approximately 25%) occurs when wetted from dry state, and minor shrinkage occurs during drying from wet state causing the formation of a minimal number of voids and small cracks	Swells greatly (approximately 600%) when wetted from dry state, and shrinks greatly when drying occurs from wet state causing the formation of extensive cracks and voids
Resistivity when wet	Relatively high, typically 3-6 Ω .m	Relatively low, typically 1-4 Ω .m (wetted)
Water retention	Good	Moderate

* Designation B3 has similar properties to B1 but with reduced resistivity.

4.4 PACKAGED ANODES

Anodes shall be packaged in a calico bag, or in some other type of porous container approved by the purchaser. The diameter of the packaging shall be at least 50 mm greater than the diagonal of the anode. The backfill shall be tightly packed in the bag to prevent movement of the anode and shall achieve the following coverage around the anode:

- (a) A minimum of 25 mm of cover on corners, measured diagonally.
- (b) A minimum of 50 mm of cover on the top, bottom and sides.

The anode type and weight shall be identified with a suitable label or tag on the outside of the calico bag.

APPENDIX A
PURCHASING GUIDELINES
(Informative)

A1 GENERAL

Australian Standards are intended to include the technical requirements for relevant products, but do not purport to comprise all the necessary provisions of a contract. This Appendix contains advice and recommendations on the information to be supplied by the purchaser at the time of enquiry or order.

A2 INFORMATION TO BE SUPPLIED BY THE PURCHASER

The purchaser should supply the following information at the time of enquiry and order, after making due reference to the explanation, advice and recommendations contained in this Appendix:

- (a) Designation of anode (see Clause 1.4.1).
- (b) Net alloy mass, specified to within +0, -5%.
NOTE: The purchaser may nominate the net alloy mass of -0, +5%.
- (c) Nominal anode shape and dimensions (see Appendix B for typical anode shapes).
- (d) Requirements of the core, to include—
 - (i) core dimensions (see Tables B2, B3, B4 and B5);
 - (ii) core finish (see Clause 2.3.2 and 2.3.3); and
 - (iii) minimum thickness for the core cover (see Clause 2.3.1).
- (e) Special cable attachment requirements (see Clause 2.3.4).
- (f) Requirements of backfill, to include—
 - (i) whether a backfill surround is required (see Clause 4.2); and
 - (ii) whether an alternative backfill composition is required (see Clause 4.2).
- (g) Whether a test certificate is required.
- (h) Whether it is the intention of the purchaser to inspect the anodes at the supplier's works.
- (i) Any additional packaging and labelling requirements.
NOTE: For backfill-surrounded anodes, the total contents are normally contained within the packaging (see Clause 4.4). Should the purchaser require special packaging or limitations on the mass of such packages, such requirements should be specified.
- (j) Reference to this Australian Standard, i.e. AS 2239.

APPENDIX B
GUIDANCE ON THE APPLICATION OF ANODES
(Informative)

B1 SCOPE

This Appendix describes the types and shapes of magnesium, zinc and aluminium anodes, and provides guidelines on how they should be selected and applied for cathodic protection.

B2 SELECTION OF ANODES

The selection of anodes for a particular application can be a complex process which requires a thorough knowledge of the following factors:

- (a) The environment.
- (b) Anode compositions.
- (c) Anode consumption rate.
- (d) Anode mass and shape.
- (e) Special considerations, including secondary deleterious effects.

Although information on the selection of anodes is usually obtained from experienced or trained personnel in the field of cathodic protection, details of the properties of anode alloys are given in Table B1, and of their characteristics and uses in Paragraphs B3 and B4.

TABLE B1
TYPICAL PROPERTIES OF GALVANIC ANODE ALLOYS

Anode alloy type	Open circuit potential, E_a		Typical anode consumption rate in sea water kg/A.year	Typical anode consumption rate in soil kg/A.year	Typical anode consumption rate hot drinking water kg/A.year
	Reference electrode				
	Cu/CuSO ₄	Ag/AgCl			
Zinc	1.1V	-1.05 to -1.15V	12	12	Not used
Magnesium:					
—high potential	-1.7V	-1.65V	Not used	7	6
—low potential	-1.5V	-1.45V	Not used	7	6
Aluminium	1.05 to -1.1V (see Note 2)	-1.00 to -1.05V	3.5	Not used	6

NOTES:

- 1 Magnesium anodes are not suitable for long term protection in sea water.
- 2 Copper sulfate reference electrodes are not recommended for prolonged use in sea water.

B3 CHARACTERISTICS AND USES OF ANODE TYPES

B3.1 Magnesium anodes

Magnesium anodes have a high negative driving potential which makes them suitable for the protection of steel structures where the environment has a high resistivity such as in soil and fresh water. Magnesium anodes are used extensively for the protection of buried pipelines, and also in hot and cold potable water applications and condensers, because their corrosion by-products are non-toxic (see also Notes to Table 2.1).

To increase efficiency in high resistivity soils, magnesium anodes are often encased in a backfill surrounding mixture contained in a calico bag, to provide a uniform low resistance environment.

B3.2 Zinc anodes

The driving potential of zinc anodes is lower than that of magnesium anodes, but is sufficient to protect steel in low resistivity environments such as occurs in some soils and sands. Zinc anodes may also be used to protect structures which are well coated and where the protective current requirements are very low. They can have extended life due to the low self-corrosion rate of zinc. Zinc anodes are also used for corrosion prevention in marine applications such as ships' hulls, offshore structures, submerged pipelines and steel and aluminium equipment.

It is important to note that at temperatures in excess of 50°C, hard non-saline waters may cause the polarity of a zinc anode/steel couple to reverse, i.e. the steel may become anodic to zinc and corrode at a rate more rapidly than that which existed prior to the installation of the anode.

B3.3 Aluminium anodes

The driving potential of aluminium anodes is similar to that of zinc anodes but, because they usually form a passive film and polarize in non-chloride environments, the use of aluminium anodes is limited mainly to marine applications such as ships' hulls, offshore structures and submerged pipelines. Aluminium anode Designation A5 (see Table 2.3) is used in hot potable water.

B4 TYPICAL MASSES, DIMENSIONS AND SHAPES OF ANODES

B4.1 General

There are two types of anodes as follows:

- (a) *Cast anodes* The cast anodes are usually in the form illustrated in Figures B1 to B8. Typical masses and dimensions of these anodes are given in Table B2, B4 and B5.
- (b) *Extruded anodes* The extruded anodes are usually in the form of rod up to 3 m long containing a mild steel core 3 mm to 5 mm in diameter. Other profiles are also available. Typical masses and dimensions of these anodes are given in Table B3.

NOTE: The net alloy mass in Table B2 is the net mass. The gross weight will be greater depending on cable length etc.

B4.2 Magnesium anodes

Magnesium anodes are supplied either as castings or as extrusions.

B4.3 Zinc anodes

Zinc anodes are usually cast, but extruded ribbon is also used. The main cast anode types are illustrated in Figures B1 to B8. Typical masses and dimensions of these anodes are given in Table B4.

B4.4 Aluminium anodes

Aluminium anodes are either cast or extruded. The main types of cast anode are illustrated in Figures B1 to B8. Typical masses and dimensions of cast aluminium anodes are listed in Table B5. Other profiles are also available.

Some industrial aluminium anodes may be as large as 350 mm × 350 mm in cross-section, as long as 3 m and may weigh up to 1 tonne (see Figure B1). These anodes usually have a steel rod core 12 mm to 25 mm in diameter, or a steel pipe core 50 mm to 150 mm in diameter.

TABLE B2
TYPICAL MASSES AND DIMENSIONS OF CAST MAGNESIUM ANODES

Anode designation	Net alloy mass kg	Nominal dimensions mm		Core dimensions mm			
		Cross-section*	Length	Diameter	Thickness	Width	Length
5M1 5M2 5M3	5	80	450	—	3 to 5	13 to 25	250
7M1 7M2 7M3	7	80	520	—	3 to 5	13 to 25	250
10M1 10M2 10M3	10	65	1 500	12	—	—	1 800
10M1 10M2 10M3	10	100	515	—	3 to 5	13 to 25	250
20M1 20M2 20M3	20	135	680	—	3 to 5	13 to 25	250

* Average cross-sectional dimensions are calculated from the expression— $\frac{1}{2}$ (width plus depth).

NOTE: For shape see Figure B1.

TABLE B3
TYPICAL MASSES AND DIMENSIONS OF EXTRUDED
MAGNESIUM ANODES

Anode designation	Net alloy mass kg	Anode diameter mm	Core diameter mm	Length mm	
(a) Round anodes (see Figure B1)					
3 M1 3 M2	3	65	3 to 5	510	
5 M1 5 M2	5	65	3 to 5	850	
7 M1 7 M2	7	65	3 to 5	1190	
10 M1 10 M2	10	65	3 to 5	1700	
20 M1 20 M2	20	65	3 to 5	3400	
20 M1 20 M2	20	89	3 to 5	1785	
(b) Bell-shaped anodes (see Figure B1)					
3 M1 3 M2	3	3 to 5	95	89	240
5 M1 5 M2	5	3 to 5	95	89	400
7 M1 7 M2	7	3 to 5	95	89	560
10 M1 10 M2	10	3 to 5	95	89	800
20 M1 20 M2	20	3 to 5	95	89	1600
20 M1 20 M2	20	3 to 5	114	120	1011
25 M1 25 M2	25	3 to 5	114	120	1264

TABLE B4
TYPICAL MASSES AND DIMENSIONS OF CAST ZINC ANODES

Anode designation	Net alloy mass kg	Shape	Nominal dimensions mm			Core dimensions mm			
			Depth	Width	Length	Diameter	Thickness	Width	Length
1Z1 1Z2	1	see Figure B3	25	25	200	1.5	—	—	600
2Z1 2Z2	2	see Figure B4	25	75	150	—	3 to 6	25	250
2Z1 2Z2	2	see Figure B5	25	100	100	—	—	—	≥29
2Z1 2Z2	2	see Figure B2	47	75	150	—	3	25	250
4Z1 4Z2	4	see Figure B5	25	150	150	—	—	—	≥29
10Z1 10Z2	10	see Figure B6	30	150	300	—	3 to 6	25	400
10Z1 10Z2	10	see Figure B6	30	150	350	—	3 to 6	25 to 30	450
12Z1 12Z2	12	see Figure B6	50	150	300	—	3 to 6	25	400
13Z1 13Z2	13	see Figure B1	35	35	1500	7	—	—	—
16Z1 16Z2	16	see Figure B7	45	115	520	—	6	40	650
20Z1 20Z2	20	see Figure B7	60	115	520	—	6	40	650
30Z1 30Z2	30	see Figure B7	60	130	560	—	6	40	700
40Z1 40Z2	40	see Figure B1	65	65	1500	12	—	—	—
60Z1 60Z2	60	see Figure B1	75	75	1500	16	—	—	—
110Z1 110Z2	110	see Figure B1	100	100	1500	20	—	—	—

TABLE B5
TYPICAL MASSES AND DIMENSIONS OF CAST ALUMINIUM ANODES

Anode designation	Net alloy mass kg	Shape	Nominal dimensions mm			Core dimensions mm			
			Depth	Width	Length	Diameter	Thickness	Width	Length
½A1 ½A2	0.4	see Figure B1	25	25	200	1.5	—	—	600
1A1 1A2	1	see Figure B2	25	75	150	—	3	25	250
1A1 1A2	1	see Figure B2	25	100	150	—	3	25	250
1A1 1A2	1	see Figure B5	25	150	150	—	—	—	≥29
3A1 3A2	3	see Figure B4	30	150	300	—	3 to 6	25	400
10A1 10A2	10	see Figure B1	50	50	1 500	12	—	—	—
15A1 15A2	15	see Figure B2	65	65	1 500	12	—	—	—
42A1 42A2	42	see Figure B1	100	100	1 500	20	—	—	—

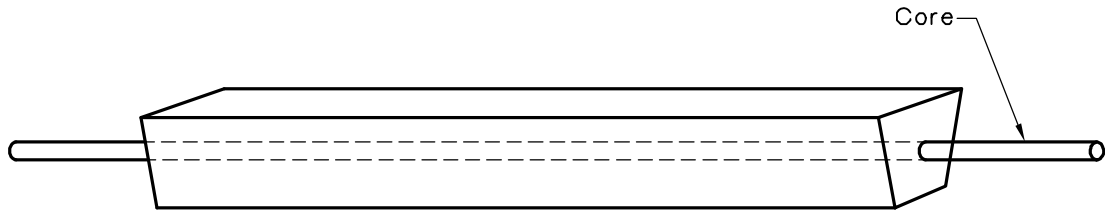

(a) Typical cast anode shape

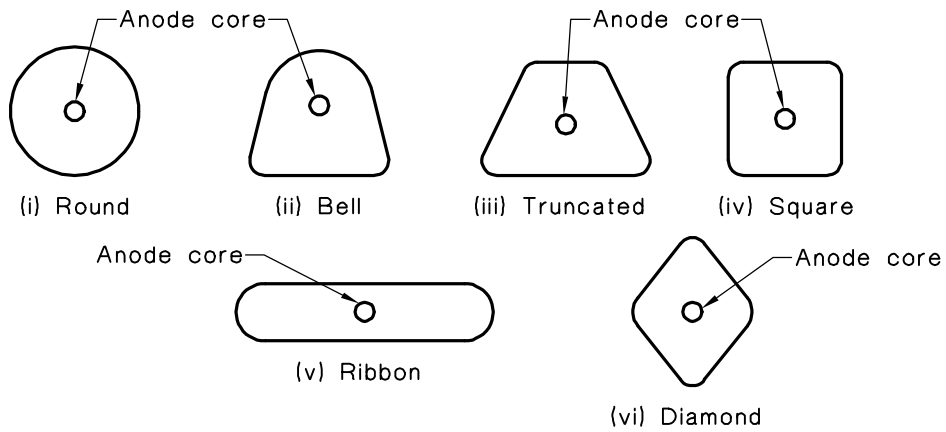

(b) Typical extruded profile shapes

FIGURE B1 TYPE OF CAST AND EXTRUDED ANODE USED FOR MAGNESIUM, ZINC OR ALUMINIUM

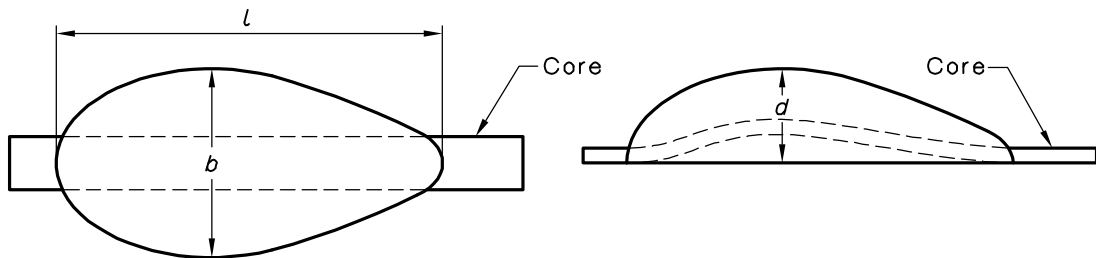

LEGEND:
 d = Thickness
 b = Width
 l = Length

FIGURE B2 TYPE OF ANODE USED FOR ZINC OR ALUMINIUM (TEAR DROP)

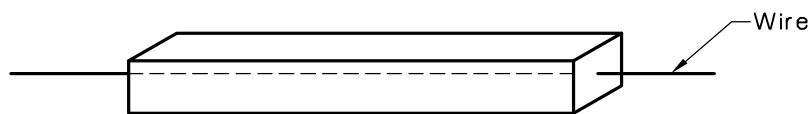

FIGURE B3 TYPE OF CAST ANODE USED FOR ZINC OR ALUMINIUM (CRAYPOT)

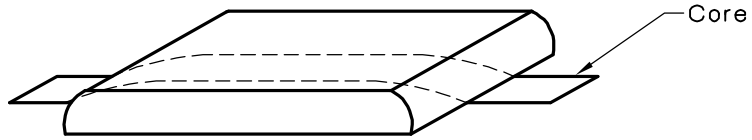
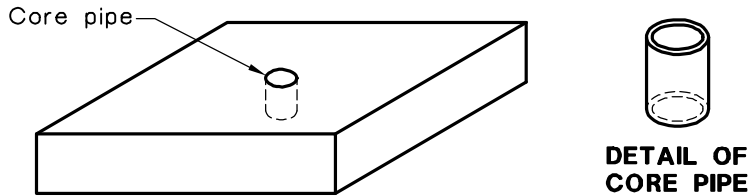

FIGURE B4 TYPE OF CAST ANODE USED FOR ZINC OR ALUMINIUM



NOTE: The core pipe protrudes 2 mm from each face.

FIGURE B5 TYPE OF CAST ANODE WITH MILD STEEL CORE PIPE USED FOR ZINC OR ALUMINIUM

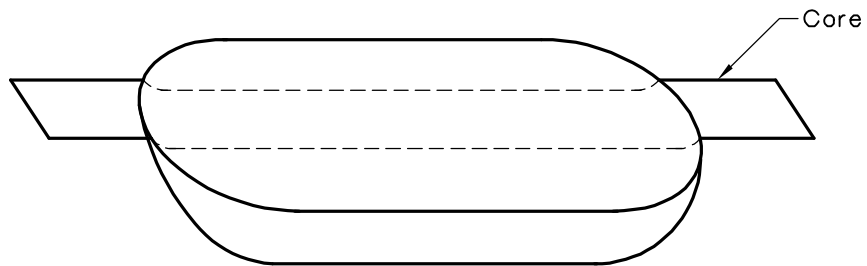
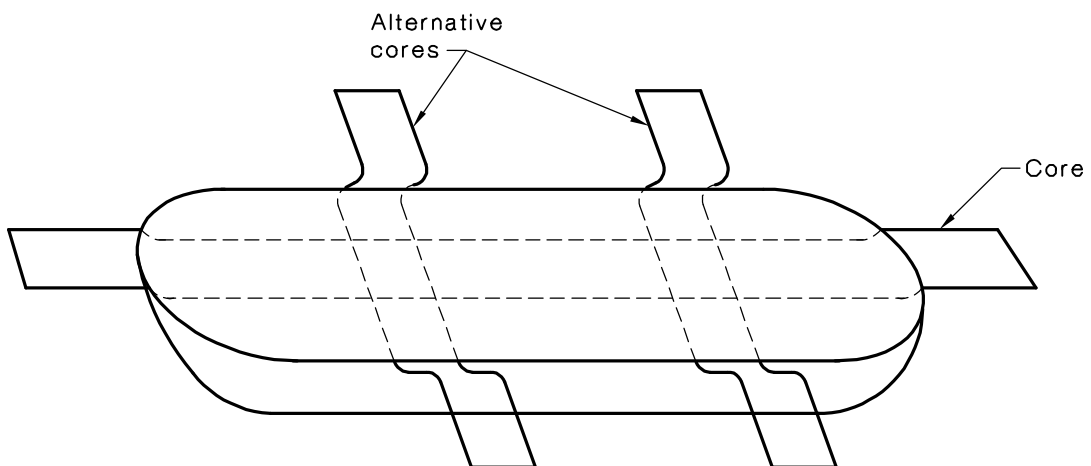

FIGURE B6 ALTERNATIVE TYPE OF CAST ANODE USED FOR ZINC OR ALUMINIUM



NOTE: The transversely placed core strips are optional to the use of the longitudinal core strip.

FIGURE B7 ALTERNATIVE TYPE OF CAST ANODE USED FOR ZINC OR ALUMINIUM SHOWING OPTIONAL CORE POSITIONS

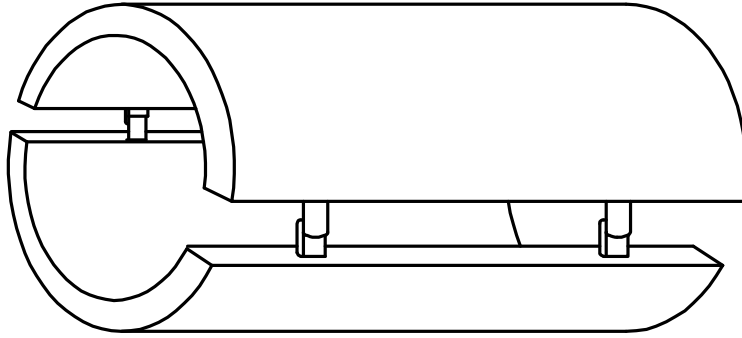

FIGURE B8 BRACELET ANODE

APPENDIX C

METHOD FOR THE DETERMINATION OF THE ANODE-TO-CORE
RESISTANCE OF GALVANIC ANODES

(Normative)

C1 GENERAL

This Appendix specifies the method for the determination of the anode-to-core resistance of galvanic (sacrificial) anodes used for cathodic protection.

C2 PRINCIPLE

The voltage across the anode metal and anode core is measured when a known current is passed between them. The anode-to-core resistance is then computed by dividing the measured voltage by the known current.

C3 APPARATUS

The following apparatus is required:

- (a) A d.c. supply of 5 A capacity, with an adjustable current control capable of smooth variation from 5 A to near zero. It shall be capable of generating an on-load-voltage sufficient to pass a current of 5 A through a resistance of not less than 1 Ω .
- (b) An ammeter capable of reading to at least 5 A d.c. with a maximum error of $\pm 1\%$ at full scale deflection, in accordance with AS 1042, Class 1. This ammeter may be integral with the d.c. supply (see Item (a)).
- (c) A millivoltmeter of the electrically protected type capable of reading to 50 mV d.c., with a maximum error of $\pm 1\%$, in accordance with AS 1042, Class 1.
- (d) Suitable test leads and clamps or clips to connect Items (a), (b) and (c) to the anode and the core. The clamp system shall be of such quality to ensure that the connection resistance to each point is less than 0.05 Ω .

C4 CIRCUIT

The circuit is arranged as shown in Figure C1 (a) or (b), as applicable. The leads connecting the millivoltmeter to the anode and the anode core (or cable), are independent of the leads from the power supply. All connections are required to be properly made to minimize contact resistance.

If the millivoltmeter is connected across the anode metal and the far end terminal of the cable attached to the anode core, the anode-to-core resistance is obtained by subtracting the cable resistance from the total resistance. The total resistance is computed by dividing the measured potential by the known current.

NOTE: The nominal resistance of 7/1.04 PVC-insulated copper cable is 3 Ω /1000 m.

C5 PROCEDURE

The test procedure shall be as follows:

- (a) Before connecting the power supply, set the variable current control to ensure a minimum current flow when the circuit is switched on.
- (b) Connect the power supply. Adjust the variable current control until approximately 5 A is registered on the ammeter.

- (c) Read the voltage difference as indicated by the millivoltmeter.
- (d) Calculate the total resistance (R), in ohms, using the following equation:

$$R = \frac{\text{millivoltmeter reading (in volts)}}{\text{ammeter reading (in amperes)}} \quad \dots \text{C5.1}$$

- (e) Reverse both the ammeter and the power supply leads and also the millivoltmeter supply leads, and repeat Steps (a) to (d) above.
NOTE: The result of this second calculation of R should be the same as the initial result.
- (f) Calculate the anode to core resistance in ohms, by subtracting the cable resistance from total resistance.

C6 REPORT

The test report shall contain the following information:

- (a) Name of test laboratory.
- (b) Identification of the equipment used to carry out the test.
- (c) Identification of the galvanic anode tested.
- (d) The date on which the test was carried out.
- (e) The results of the anode-to-core resistance test calculations.
- (f) Reference to this test method, i.e. AS 2239, Appendix C.

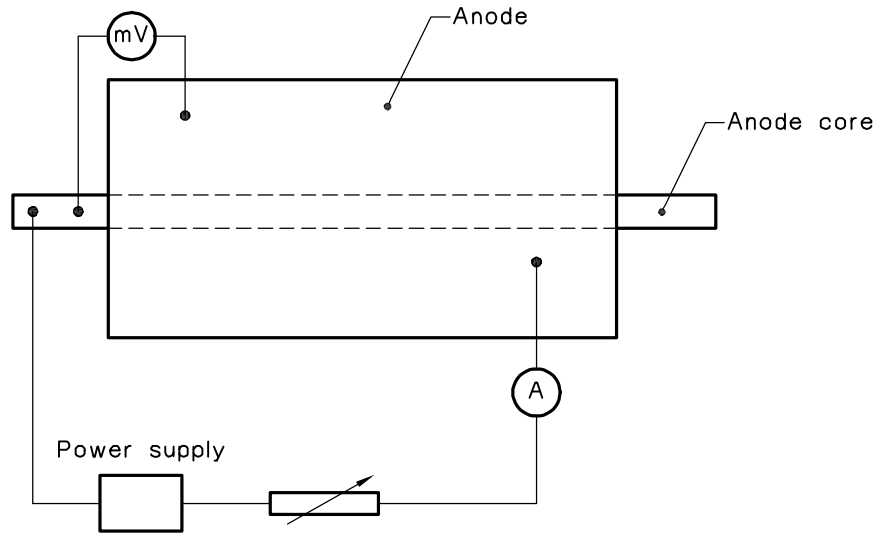

(a) Without cable attached

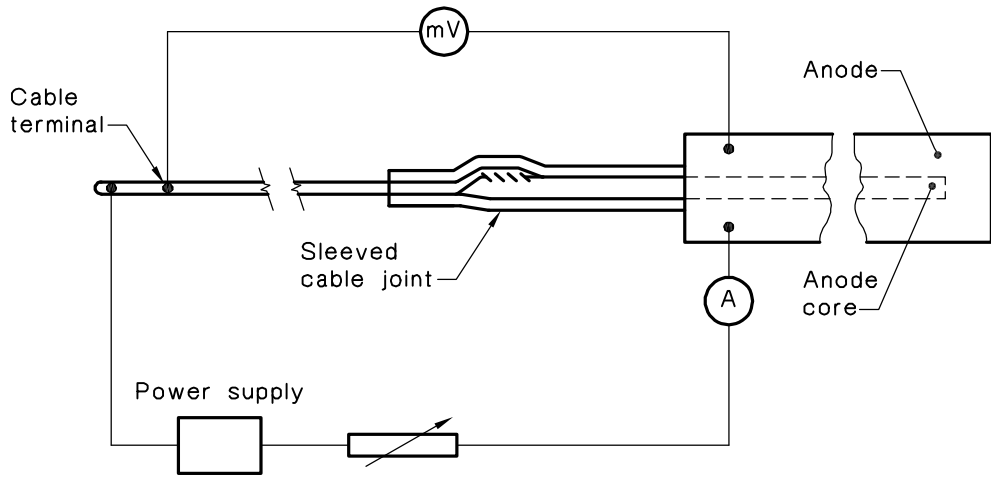

(b) With cable attached

FIGURE C1 SCHEMATIC CIRCUITS FOR MEASUREMENT OF ANODE-TO-CORE RESISTANCE

APPENDIX D

METHOD FOR THE DETERMINATION OF THE CONSUMPTION RATE OF ALUMINIUM ANODE ALLOYS IMMERSSED IN SEA WATER

(Normative)

D1 GENERAL

This Appendix specifies the method for the determination of the consumption rate of aluminium anode alloys intended for use in cathodic protection of ferrous metals immersed in sea water.

NOTE: The anode alloy consumption rate, expressed in kilograms per ampere year, is normally used as a Quality Assurance check on different melts on the one alloy (especially alloys A1 and A2 in Table 2.3). The consumption rate may be used to compute the current capacity of an anode system.

D2 PRINCIPLE

The loss of anode mass, which occurs during the flow of a known quantity of imposed current during the test from the anode to the cathode in sea water, is computed to show the quantity of anode metal consumed in one year by the passage of 1A.

NOTE: About 20% of the mass loss is due to anodic dissolution inefficiency. The associated current cannot be detected by the apparatus in D3(a) and (b) below.

D3 APPARATUS

The following apparatus is required:

- (a) A constant current d.c. power supply with an output voltage appropriate to the number of test cells in series, and having sufficient current capacity to maintain the specified anode current density. The output current stability of the power supply shall be within 1%.
- (b) An ammeter to suit the current requirement, and having a maximum error of +1%, in accordance with AS 1042, Class 1. This ammeter may be integral with the power supply (see Item (a)).
- (c) Aluminium or stainless steel cathodes; one per aluminium anode (or one each side of the anode, connected together).

NOTE: A convenient anode test-piece would be cylindrical, 150 mm long and 25 mm diameter. Other simple shapes and dimensions compatible with tank geometry may be used, provided all anodes in a test have the same dimensions and their geometrical surface area is readily calculated.

- (d) Non-metallic tanks; one per anode, to hold sea water.
NOTE: Close fitting tank covers may be used to reduce evaporation.
- (e) Clean sea water with a resistivity of not greater than 0.3 Ω .m at 20°C, or synthetic sea water conforming to the requirements of ASTM D1141.
- (f) An agitator suitable for gentle motion and circulation of the electrolyte.
NOTE: The purpose is to dissipate gas from the anode surface and to ensure the seawater is consumed uniformly.

D4 CIRCUIT

The circuit shall be arranged as shown in Figure D1.

D5 PREPARATION OF TEST ANODES

The as-manufactured anode surface profile is preferred for test purposes, but cut and machined surfaces are not excluded.

All anodes used in the same test series have the same nominal composition and the same initial area dimensions exposed to the sea water.

Any mounting strap or wiring conductor shall be covered to prevent contact with cleaning acid or with sea water during the test period.

The anodes shall be immersed in nitric acid (ρ_{20} 1420 kg/m³) at ambient temperature until visibly clean and then thoroughly rinsed in clean fresh water and dried. Anodes may be preserved in this condition in tightly closed plastic or glass containers.

D6 PROCEDURE

The anode consumption rate shall be determined as follows:

- (a) Weigh each anode and record its mass, to $\pm 1\%$ accuracy.
- (b) Connect the circuit as shown in Figure D1, checking the tanks are in series electrically.
- (c) Adjust the power supply to produce a current output equivalent to a current density of between 0.5 mA/cm² and 0.7 mA/cm² for each anode in the one test. Record the time and date of commencement of the test and the set current value.

NOTE: The anode surface area to be used to obtain current density is calculated from the initial dimensions of that anode.

- (d) Change the sea water when 0.1 A.h has passed for each 1 L of sea water in a cell.

NOTE: Record periods when changing the sea water.

- (e) Continue the test for a period of at least 10 days. Sum the periods of time that current was passing.

NOTE: The longer the test period the more reliable will be the result but care may be needed that anode identification marks persist during the extended testing periods. Long test periods producing easily visible reduction of anode size should be avoided since the set current may correspond to current densities greater than the desirable maximum.

- (f) Remove the test anodes from the cells. Record the time and date. Clean, rinse and dry the test anodes in accordance with Paragraph D5, and reweigh.
- (g) Calculate the alloy consumption rate for each anode, in kilograms per ampere year, using the following equation:

$$\text{Alloy consumption rate} = \frac{\text{mass loss} \times 8760}{\text{total current flow}} \quad \dots \text{D6.1}$$

where

mass loss is in kilograms

total current flow is in ampere hours

Express the result to the nearest 0.1 kg/A.year.

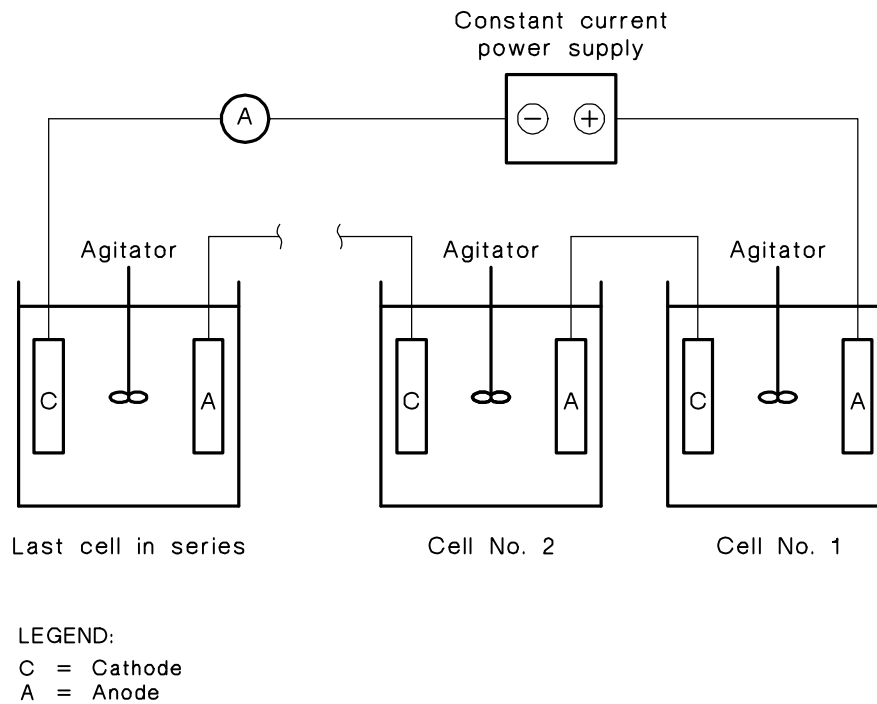

FIGURE D1 SCHEMATIC CIRCUIT FOR DETERMINATION OF ALLOY CONSUMPTION RATE

D7 REPORT

The report shall contain the following information:

- (a) Name of the test laboratory.
- (b) Identification of the equipment, including sea water used to carry out the test.
- (c) Identification of the anode material.
- (d) The mass of each anode before and after completion of the test.
- (e) Other test details including the test period.
- (f) The dates during which the test was carried out.
- (g) The test results. Consumption rates over 3.5 kg/A. year. merit anode rejection.

NOTE: Typically consumption rates are 5% to 10% less than this figure, under these test conditions.

- (h) Reference to this test method, i.e. AS 2239, Appendix D.

APPENDIX E

METHOD FOR THE DETERMINATION OF THE CLOSED-CIRCUIT
POTENTIAL OF ALUMINIUM ANODES IMMERSSED IN SEA WATER

(Normative)

E1 GENERAL

This Appendix specifies the method for the determination of the closed-circuit potential of aluminium anodes intended for use in the cathodic protection of ferrous metals immersed in sea water.

NOTE: The closed-circuit potential, as distinct from the open-circuit potential, is a critical factor when assessing the ability of galvanic anodes to protect ferrous metal structures in service (see AS/NZS 1125).

E2 PRINCIPLE

The closed-circuit potential is measured when current is flowing between an anode and cathode in sea water, by locating a reference cell close to the anode surface.

E3 APPARATUS

The following apparatus is required:

- (a) A 12 V d.c. power source with a variable resistance to maintain the specified anode current density.
- (b) A suitable ammeter.
- (c) A high resistance voltmeter with a minimum input resistance of 10 M Ω /V and a resolution of 10 mV or better, and having a maximum error of $\pm 1\%$ at full scale deflection.
- (d) A silver/silver chloride or saturated calomel reference electrode.
- (e) An aluminium or stainless steel cathode.
- (f) A non-metallic tank to hold sea water.
- (g) Fixed resistors of equal value. The voltage drop across each fixed resistor shall be at least 10 V.
- (h) Clean sea water with a resistivity of not greater than 0.3 Ω .m at 20°C, or synthetic sea water conforming to the requirements of ASTM D1141.

E4 CIRCUIT

The circuit shall be arranged as shown in Figure E1 to enable the testing of one or a series of anodes. All anodes in the circuit shall have the same nominal composition and shape and the same area dimensions exposed to the sea water.

Any immersed part of mounting strap, wiring conductor or anode shall be insulated to avoid contact with sea water.

E5 PREPARATION OF TEST ANODE

For test purposes, it is preferred that the surface of the anode is in the as-manufactured condition, however cut and machined surfaces are also acceptable.

E6 PROCEDURE

The closed-circuit potential shall be determined using the following procedure:

- Arrange the equipment so that the anode-to-cathode distances are approximately the same, and the current flow is not affected by cell geometry or adjacent anodes.
- Adjust the test anode current density to a value between 0.5 mA/cm^2 and 0.7 mA/cm^2 and record the time of commencement of current flow. Change the sea water when 0.1 A.h has passed for each litre of sea water contained in the tank.
- Record, to the nearest 0.01 V, the closed-circuit potential on the voltmeter. Continue the test until three consecutive stable readings are obtained at time intervals of 1 h.
- Report the last three stable closed-circuit potential readings obtained with respect to the reference cell, for each anode under test.
- Repeat Steps (a) to (d) for each anode tested to enable duplication of the results.

E7 REPORT

The report shall contain the following information:

- Name of the test laboratory.
- Identification of the equipment used to carry out the test, the reference cell, details of the circuit and details of the sea water used.
- Identification of the anode material, and number and dimensions of anodes in the circuit.
- The current density used, test procedure details and resultant closed circuit potential readings (in duplicate).
- The date of testing.
- Reference to this test method, i.e. AS 2239, Appendix E.

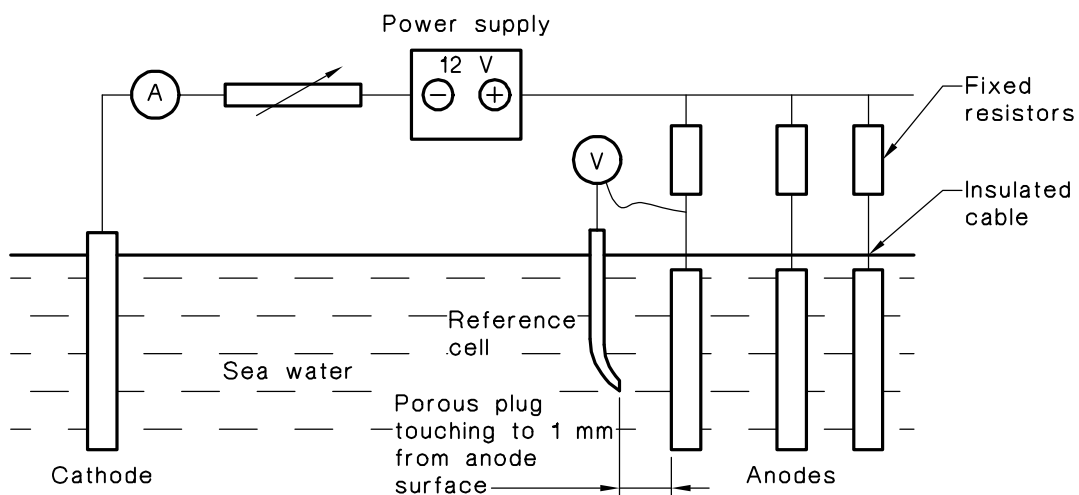

FIGURE E1 SCHEMATIC CIRCUIT FOR MEASUREMENT OF CLOSED-CIRCUIT POTENTIAL

NOTES

Standards Australia

Standards Australia is an independent company, limited by guarantee, which prepares and publishes most of the voluntary technical and commercial standards used in Australia. These standards are developed through an open process of consultation and consensus, in which all interested parties are invited to participate. Through a Memorandum of Understanding with the Commonwealth government, Standards Australia is recognized as Australia's peak national standards body.

Australian Standards

Australian Standards are prepared by committees of experts from industry, governments, consumers and other relevant sectors. The requirements or recommendations contained in published Standards are a consensus of the views of representative interests and also take account of comments received from other sources. They reflect the latest scientific and industry experience. Australian Standards are kept under continuous review after publication and are updated regularly to take account of changing technology.

International Involvement

Standards Australia is responsible for ensuring that the Australian viewpoint is considered in the formulation of international Standards and that the latest international experience is incorporated in national Standards. This role is vital in assisting local industry to compete in international markets. Standards Australia represents Australia at both ISO (The International Organization for Standardization) and the International Electrotechnical Commission (IEC).

Electronic Standards

All Australian Standards are available in electronic editions, either downloaded individually from our Web site, or via on-line and CD ROM subscription services. For more information phone 1300 65 46 46 or visit us at

www.standards.com.au



GPO Box 5420 Sydney NSW 2001

Administration Phone (02) 8206 6000 Fax (02) 8206 6001 Email mail@standards.com.au

Customer Service Phone 1300 65 46 46 Fax 1300 65 49 49 Email sales@standards.com.au

Internet www.standards.com.au