

COMBINATION SET - Individual Components Shown At Top - Plug Material: DEZINCIFICATION RESISTANT BRASS

This drawing is the property of Cathodic Anodes Australasia. To be used with permission only. This drawing becomes an uncontrolled document once issued as hard or electronic copy. Customer to confirm current revision of drawing prior to ordering.

Zinc Anode Only - CAA Part No: CDZ9-004 (Drawing No: CDQ-101)

D.R. Brass Plug 03 (BP03)

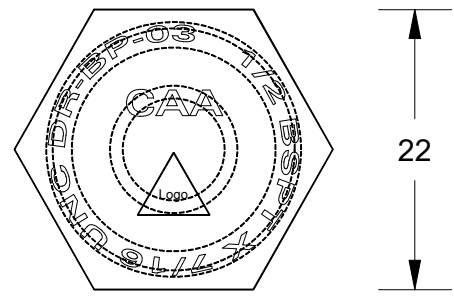
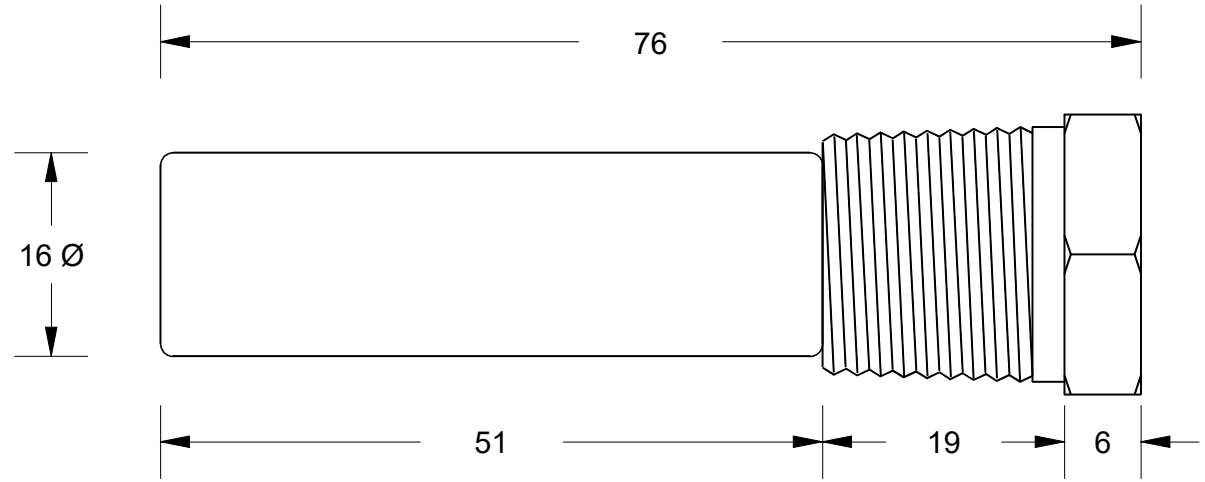
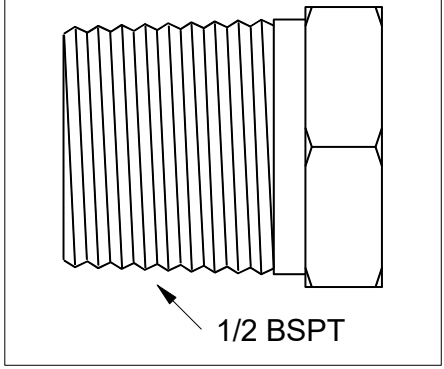
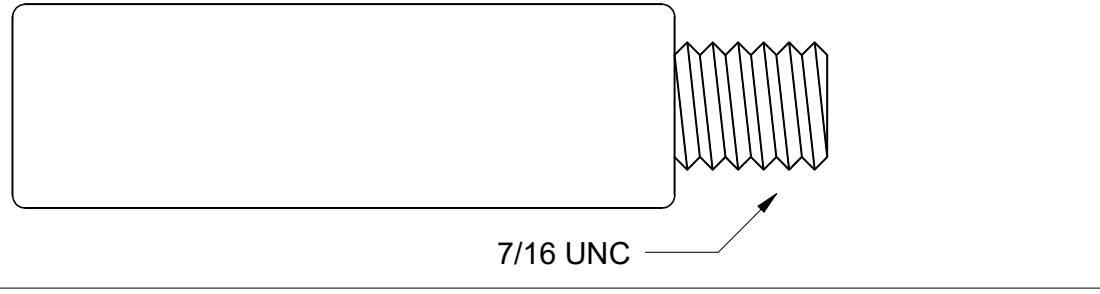

NO SHARP EDGES

 = Australian Made Logo

All dimensions are in mm (nominal)

Chemical Composition Limits		
Standard: AS2239* (Most current revision)		
Zinc		
Element	min.	max.
Cadmium	0.025	0.07
Aluminium	0.10	0.50
Silicon	-	0.005
Copper	-	0.005
Iron	-	0.005
Lead	-	0.006
Other Impurities		
- each	-	0.005
- total	-	0.02
Zinc	remainder	

Alloy: **Z1**

- Notes
- Anodes are cast to comply with CAA's standard casting tolerances
 - All sharp edges removed for safe handling
 - Anode insert material to meet relevant Australian/International specifications



Rev	Details of Change(s)	Date	Drawn	Verified
1	Cathodic Diecasting Original	13 July 2004	GPC	R.G.
2	2013 Catalogue Version (CAA Logo)	13 April 2015	R.N.	R.G.
3	Stamping & Logo added to DR Brass Plug	10 Nov 2020	R.N.	R.G.
4	Updated drawing information	24 Feb 2022	B.G.	

Nett Weight Kg (nominal)	Gross Weight Kg (nominal)
0.070	0.130



Cathodic Anodes Australasia

cathodicanodes.com.au

Product	
Zinc Anode & DR Brass Plug	
Part no.	Scale
CDZ9-036	1.75 : 1
Drawing No: CDQ-161	Rev Sheet
	4 1 of 1
Drawn by: R Northey	Date: 10 NOV 2020
	

* Corresponds to MIL-DTL-18001L alloy composition