

This drawing is the property of Cathodic Anodes Australasia. To be used with permission only. This drawing becomes an uncontrolled document once issued as hard or electronic copy. Customer to confirm current revision of drawing prior to ordering.

"A" - Tack Weld 3mm Ø x 25 long wire to the insert, anchor system, 25 %, 50 % and 75 %, approximately.

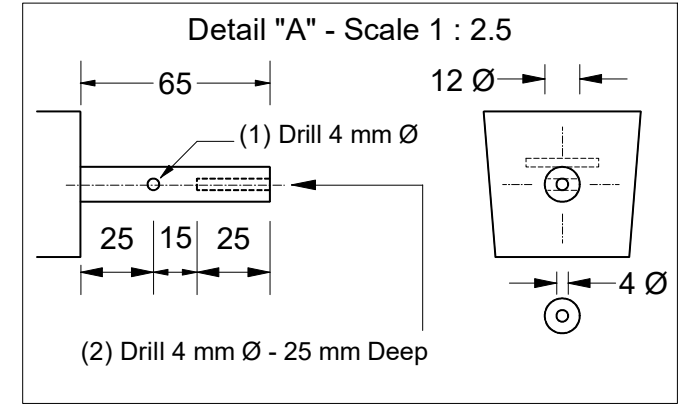
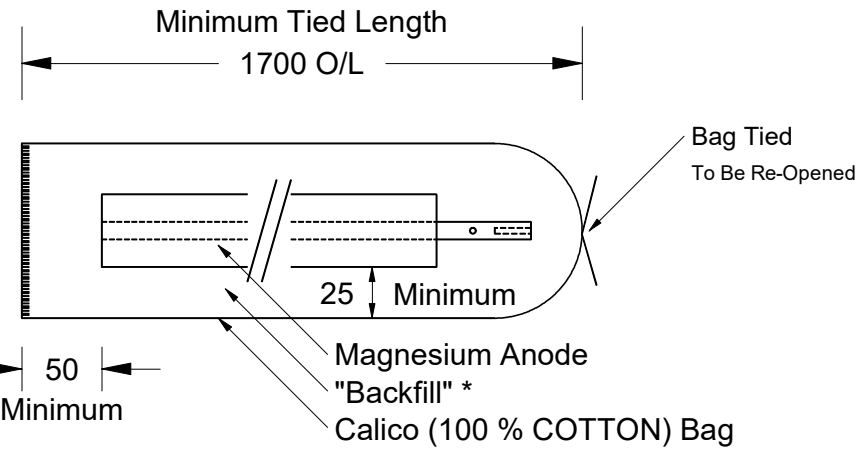
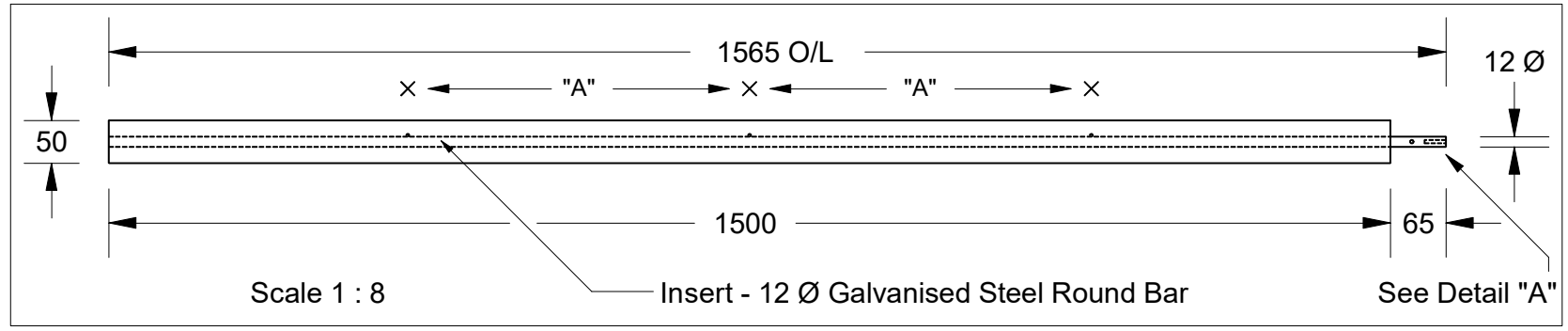
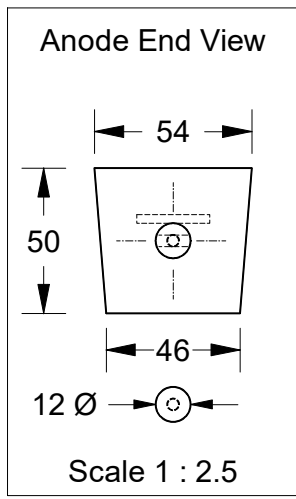

- Notes
- Anodes are cast to comply with CAA's standard casting tolerances
 - All sharp edges removed for safe handling
 - Anode insert material to meet relevant Australian/International specifications

**"Backfill" Composition 45% Gypsum, 50% Calcium Bentonite, 5% Sodium Sulphate

To Suit Cable Type:
6 mm Square "SDI"
Single Core Double Insulated
Normally 10 m Cable - Red Inner & White Outer

Chemical Composition Limits			Alloy: M1C
Standard: ASTM B843 (Most current revision)			
Magnesium, High Potential			
Element	min.	max.	
Aluminium	-	0.01	
Zinc	-	0.02	
Manganese	0.50	1.3*	
Silicon	-	0.05	
Copper	-	0.02	
Iron	-	0.03	
Nickel	-	0.001	
Calcium	-	0.04	
Other Impurities			
- each	-	0.05	
- total	-	0.30	
Magnesium	remainder		

Density of Cast Magnesium Anode Alloys	
M1C (calculated mean)	1.73 g / cm ³
M3 (calculated mean)	1.94 g / cm ³

Anode & Insert					
Nett Weight		Gross Weight			
Kg (nominal)		Kg (nominal)			
6.2		7.6			

Rev	Details of Change(s)	Date	Initials	Verified	Initials
1	For Quotation	09 MAR 15	R.N.	09 MAR 15	J.L.
2	3 x (3 mm x 25) Wire Anchors added to insert.	21 APR 15	R.N.	21 APR 15	J.L.

CAA
Cathodic Anodes Australasia
cathodicanodes.com.au

Product Magnesium Anode		Scale N.T.S.	
Part no. CDM - 8P (M1C)		Rev Sheet 2 1 of 1	
Drawing No: CD3938		Rev Sheet 2 1 of 1	
Drawn by: R Northey Date: 21 APR 2015		Rev Sheet 2 1 of 1	
All dimensions are in mm (nominal)			