

This drawing is the property of Cathodic Anodes Australasia. To be used with permission only.  
 This drawing becomes an uncontrolled document once issued as hard or electronic copy.  
 Customer to confirm current revision of drawing prior to ordering.

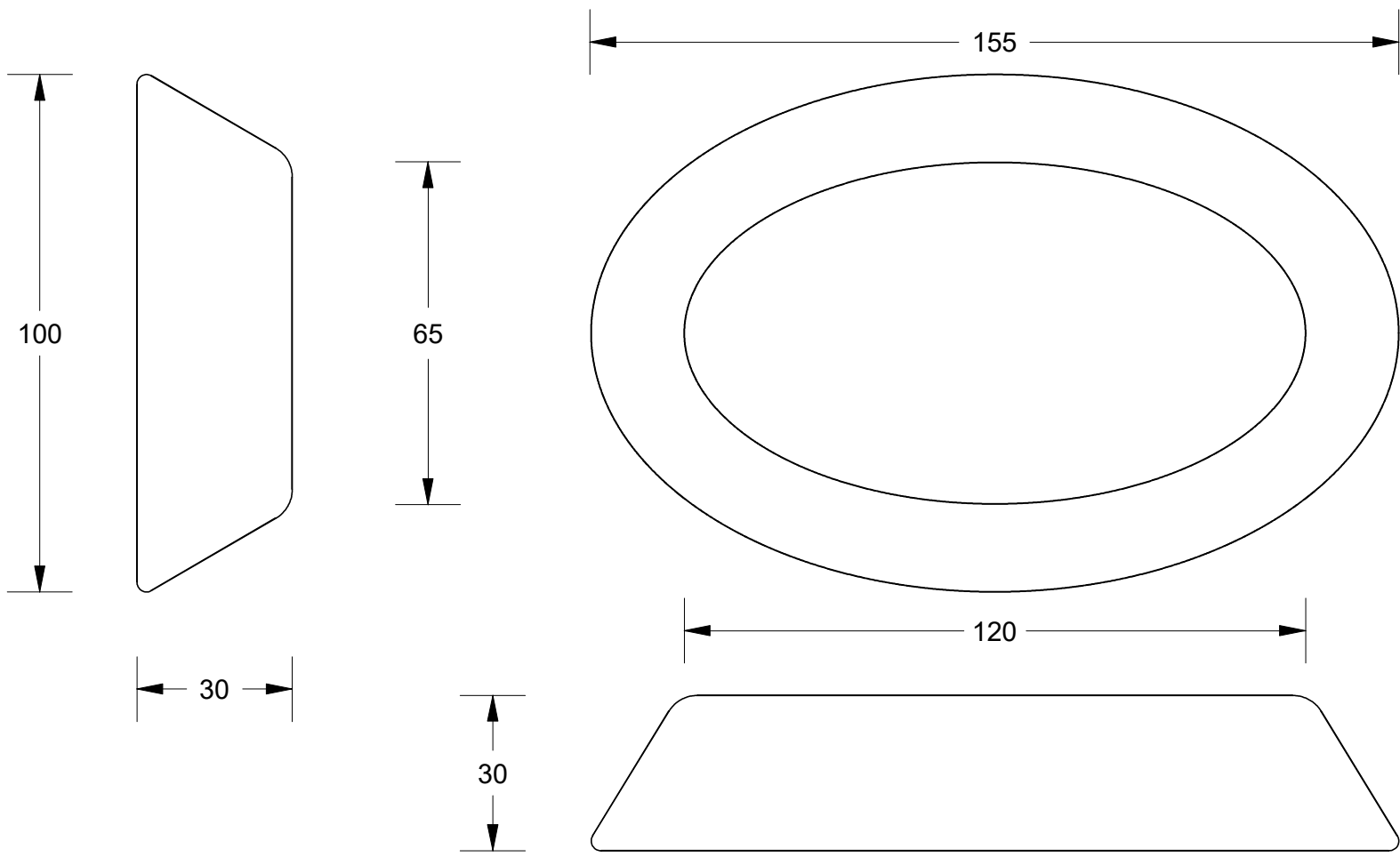

Chemical Composition Limits			Alloy:
Standard: AS2239* (Most current revision)			<b>Z1</b>
Zinc			
Element	min.	max.	
Cadmium	0.025	0.07	
Aluminium	0.10	0.50	
Silicon	-	0.005	
Copper	-	0.005	
Iron	-	0.005	
Lead	-	0.006	
Other Impurities			
- each	-	0.005	
- total	-	0.02	
Zinc	remainder		

\* Corresponds to MIL-DTL-18001L alloy composition

- Notes
1. Anodes are cast to comply with CAA's standard casting tolerances
  2. All sharp edges removed for safe handling
  3. Anode insert material to meet relevant Australian/International specifications



Rev	Details of Change(s)	Date	Drawn	Verified
1	For Manufacture	18 March 2014	R.N.	D.K.

Nett Weight Kg (nominal)	Gross Weight Kg (nominal)
<b>1.95</b>	<b>N/A</b>

**CAA**  
Cathodic Anodes Australasia

[cathodicanodes.com.au](http://cathodicanodes.com.au)

Product		<b>Zinc Anode</b>	
Part no.	<b>Blackwatch Anode</b>	Scale	<b>1 : 1.25</b>
Drawing No:	<b>CD3771</b>	Rev	Sheet
		<b>1</b>	<b>1 of 1</b>
Drawn by: R Northey	Date: 18 MAR 2014		
Mould No: N/A	Tooling: N/A		

All dimensions are in mm (nominal)