

Sheet 2 - Machining Detail - Identical Halves

This drawing is the property of Cathodic Anodes Australasia. To be used with permission only. This drawing becomes an uncontrolled document once issued as hard or electronic copy. Customer to confirm current revision of drawing prior to ordering.

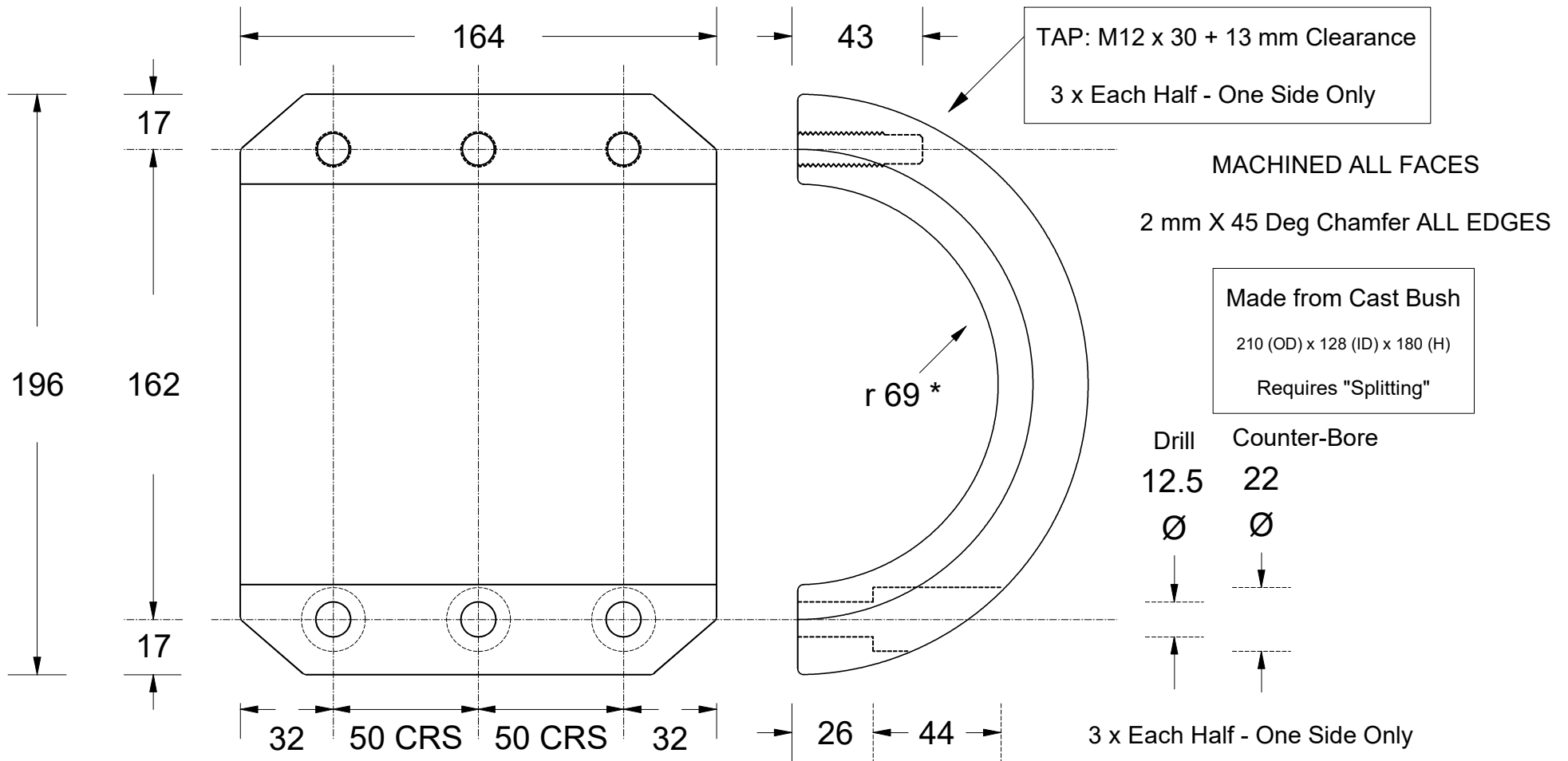

Chemical Composition Limits		Alloy:
Standard: AS2239* (Most current revision)		Z1
Zinc		
Element	min.	max.
Cadmium	0.025	0.07
Aluminium	0.10	0.50
Silicon	-	0.005
Copper	-	0.005
Iron	-	0.005
Lead	-	0.006
Other Impurities		
- each	-	0.005
- total	-	0.02
Zinc	remainder	

* Corresponds to MIL-DTL-18001L alloy composition

Notes

- Anodes are cast to comply with CAA's standard casting tolerances
- All sharp edges removed for safe handling
- Anode insert material to meet relevant Australian/International specifications



Rev	Details of Change(s)	Date	Drawn	Verified
1	Original Generic - NTS	24 January 2013	R.N.	R.G.
2	Manufactured in 2013	28 March 2013	R.N.	R.G.
3	Revision & Audit 2016	22 January 2016	R.N.	R.G.

All dimensions are in mm (nominal)

 Cathodic Anodes Australasia cathodicanodes.com.au		Product	
		Zinc Anode - Shaft Anode	
Part no.		Scale	
CDZ4 - 550 Type 2		1 : 2	
Drawing No: CD3546		Rev	Sheet
		3	2 of 2
Drawn by: R Northey Date: 22 JAN 2016			