

This drawing is the property of Cathodic Anodes Australasia. To be used with permission only. This drawing becomes an uncontrolled document once issued as hard or electronic copy. Customer to confirm current revision of drawing prior to ordering.

4 x M12 x 50mm 304 S/S Socket Head Cap Screws, 4 x M12 304 S/S Internal Tooth Washers

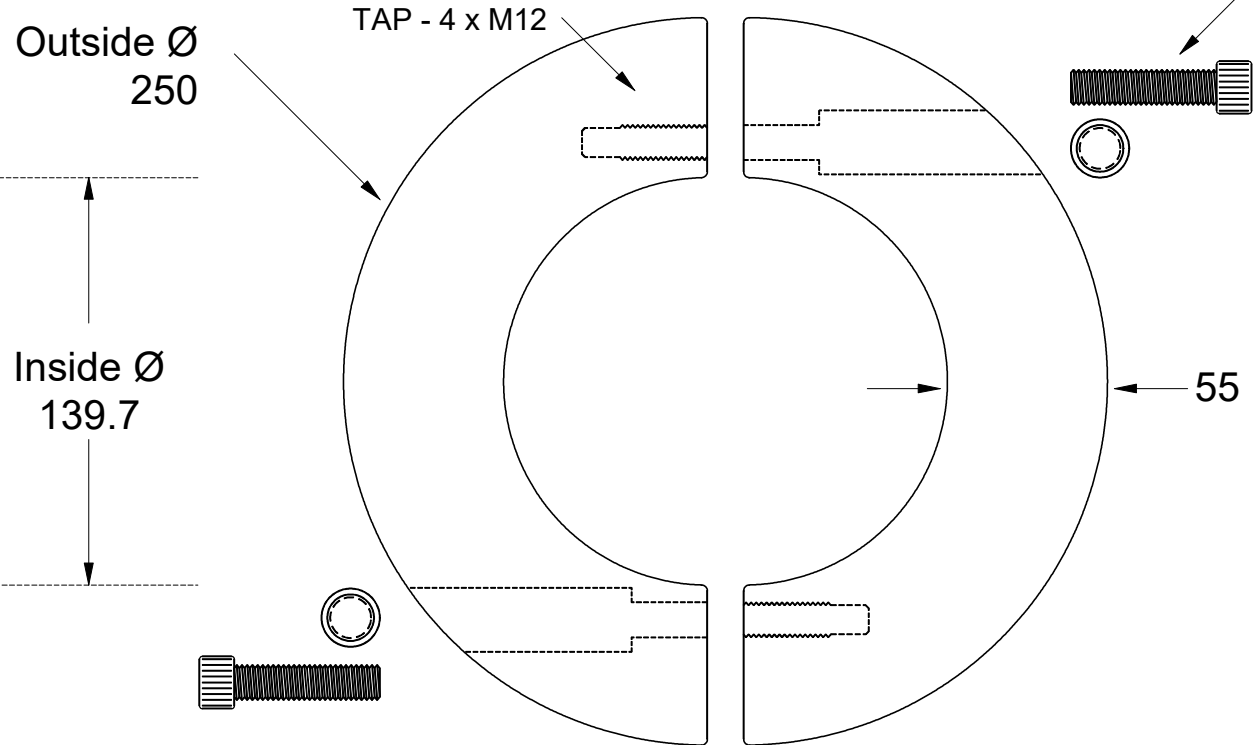
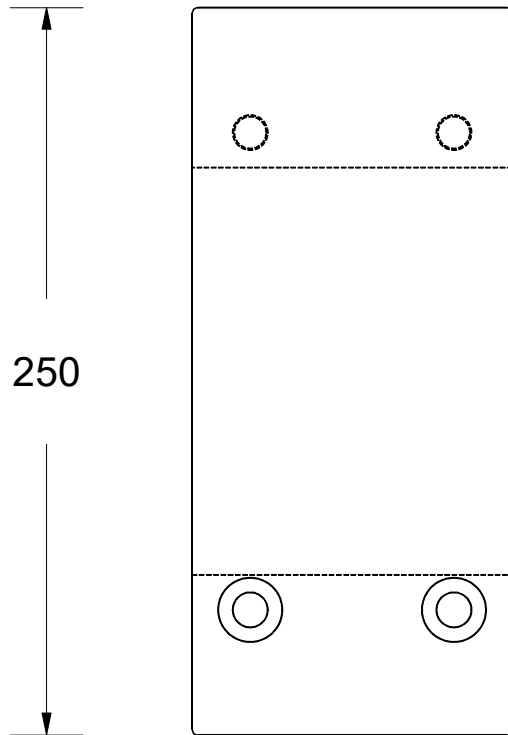

Intended Use For 5-1/2" IMPERIAL Shafts - See Sheet 2 for Machining Detail

Casting Note: Made from a 250 (OD) x 128 (ID) x 120 (H) Cast Bush - Split by Machine Shop

All dimensions are in mm (nominal)

Chemical Composition Limits		Alloy:
Standard: AS2239* (Most current revision)		Z1
Element	min.	max.
Cadmium	0.025	0.07
Aluminium	0.10	0.50
Silicon	-	0.005
Copper	-	0.005
Iron	-	0.005
Lead	-	0.006
Other Impurities		
- each	-	0.005
- total	-	0.02
Zinc		remainder

* Corresponds to MIL-DTL-18001L alloy composition

Notes

1. Anodes are cast to comply with CAA's standard casting tolerances
2. All sharp edges removed for safe handling
3. Anode insert material to meet relevant Australian/International specifications



Rev	Details of Change(s)	Date	Drawn	Verified
1	Cathodic Diecasting Original	17 May 2012	R.N.	R.G.
2	2013 Catalogue Version (CAA Logo)	22 January 2016	R.N.	R.G.

Nett Weight	Gross Weight
Kg (nominal)	Kg (nominal)
26.7	27.0



Cathodic Anodes Australasia

cathodicanodes.com.au

Product	
Zinc Anode - Shaft Anode	
Part no.	Scale
CDZ4 - 550	1 : 2.5
Drawing No:	Rev Sheet
CD3407	2 1 of 2
Drawn by: R Northey	Date: 22 JAN 2016

