

Sheet 2 - Machining Detail - Identical Halves

This drawing is the property of Cathodic Anodes Australasia. To be used with permission only. This drawing becomes an uncontrolled document once issued as hard or electronic copy. Customer to confirm current revision of drawing prior to ordering.

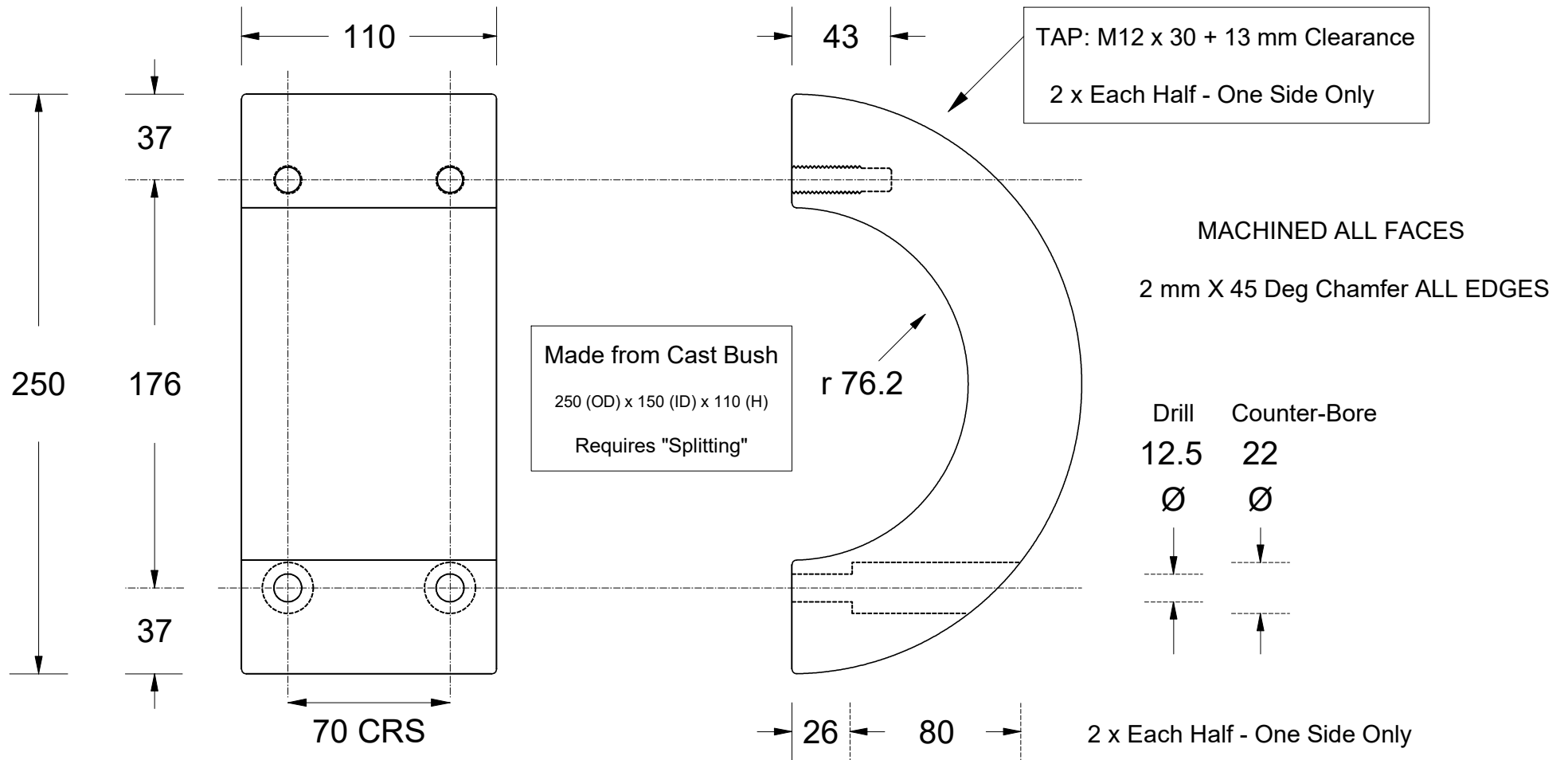

Chemical Composition Limits		Alloy:
Standard: AS2239* (Most current revision)		Z1
Zinc		
Element	min.	max.
Cadmium	0.025	0.07
Aluminium	0.10	0.50
Silicon	-	0.005
Copper	-	0.005
Iron	-	0.005
Lead	-	0.006
Other Impurities		
- each	-	0.005
- total	-	0.02
Zinc	remainder	

* Corresponds to MIL-DTL-18001L alloy composition

Notes

- Anodes are cast to comply with CAA's standard casting tolerances
- All sharp edges removed for safe handling
- Anode insert material to meet relevant Australian/International specifications



Rev	Details of Change(s)	Date	Drawn	Verified
1	For Quotation	22 January 2016	R.N.	R.G.

All dimensions are in mm (nominal)

		Product	
		Zinc Anode - Shaft Anode	
Part no.		Scale	
CDZ4 - 600		1 : 2.5	
Drawing No: CD3369		Rev	Sheet
		1	2 of 2
Drawn by: R Northey Date: 22 JAN 2016			
cathodicanodes.com.au			