

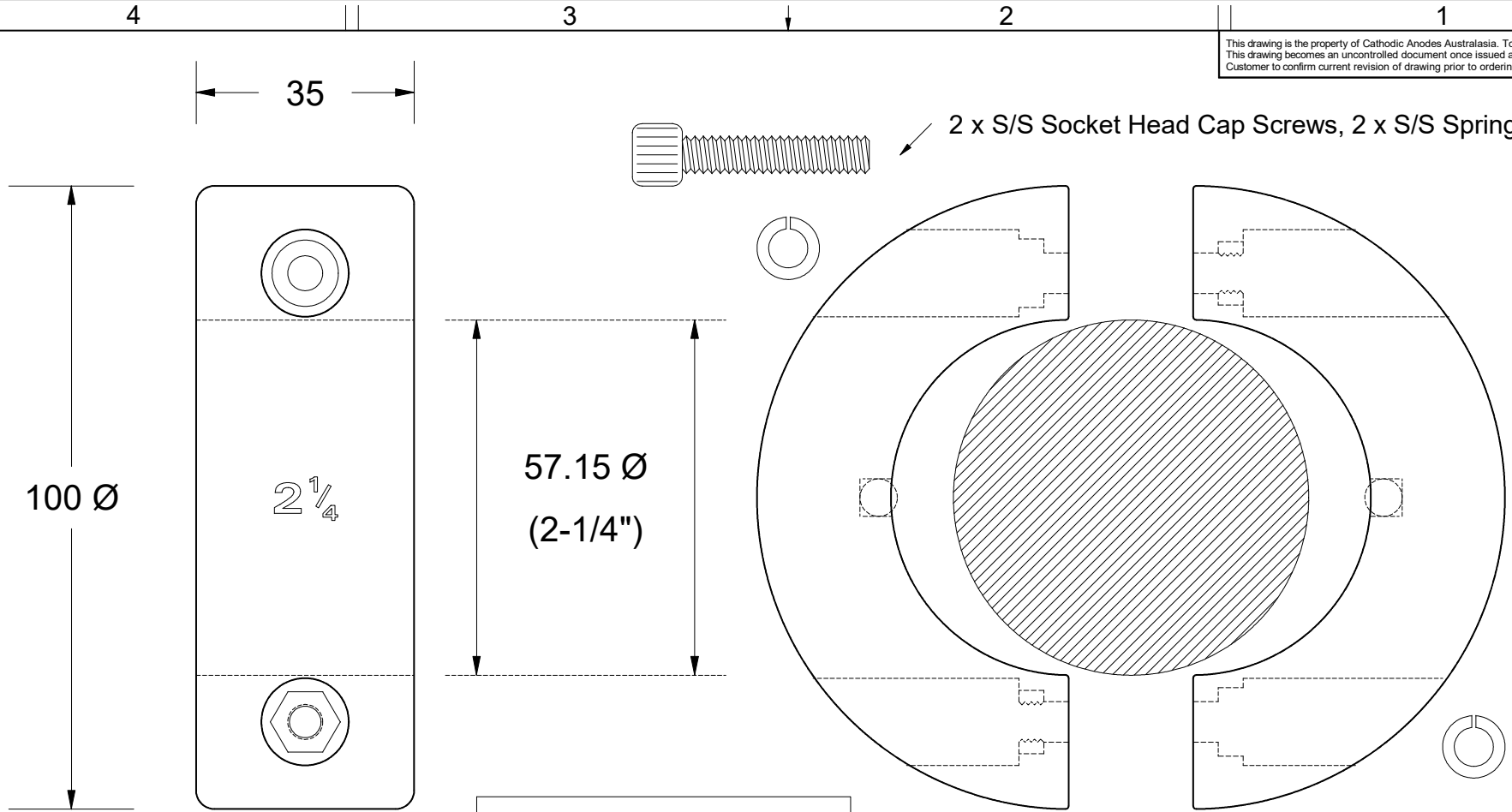





This drawing is the property of Cathodic Anodes Australasia. To be used with permission only.  
 This drawing becomes an uncontrolled document once issued as hard or electronic copy.  
 Customer to confirm current revision of drawing prior to ordering.



   
   
 2 x "Cast In" S/S Hex Nuts

  
 2 x Copper Contacts

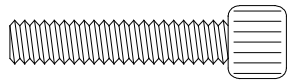

Chemical Composition Limits		Alloy:
Standard: AS2239* (Most current revision)		<b>Z1</b>
Zinc		
Element	min.	max.
Cadmium	0.025	0.07
Aluminium	0.10	0.50
Silicon	-	0.005
Copper	-	0.005
Iron	-	0.005
Lead	-	0.006
Other Impurities		
- each	-	0.005
- total	-	0.02
Zinc	remainder	

\* Corresponds to MIL-DTL-18001L alloy composition

- Notes
1. Anodes are cast to comply with CAA's standard casting tolerances
  2. All sharp edges removed for safe handling
  3. Anode insert material to meet relevant Australian/International specifications

Rev	Details of Change(s)	Date	Drawn	Verified
1	Cathodic Diecasting Original	13 September 2011	R.N.	R.G.
2	2013 Catalogue Version (CAA Logo)	29 January 2016	R.N.	R.G.

Nett Weight Kg (nominal)	Gross Weight Kg (nominal)
<b>1.185</b>	<b>1.200</b>



**Cathodic Anodes Australasia**  
[cathodicanodes.com.au](http://cathodicanodes.com.au)

Product		<b>Zinc Anode - DONUT Shaft Anode</b>	
Part no.	Scale		
<b>CDZ4 - 225D</b>	<b>1 : 1</b>		
Drawing No:	Rev	Sheet	
<b>CD3207</b>	<b>2</b>	<b>1 of 1</b>	
Drawn by: R Northey		Date: 29 JAN 2016	

All dimensions are in mm (nominal)