

Sheet 2 - Machining Detail - Identical Halves

This drawing is the property of Cathodic Anodes Australasia. To be used with permission only. This drawing becomes an uncontrolled document once issued as hard or electronic copy. Customer to confirm current revision of drawing prior to ordering.

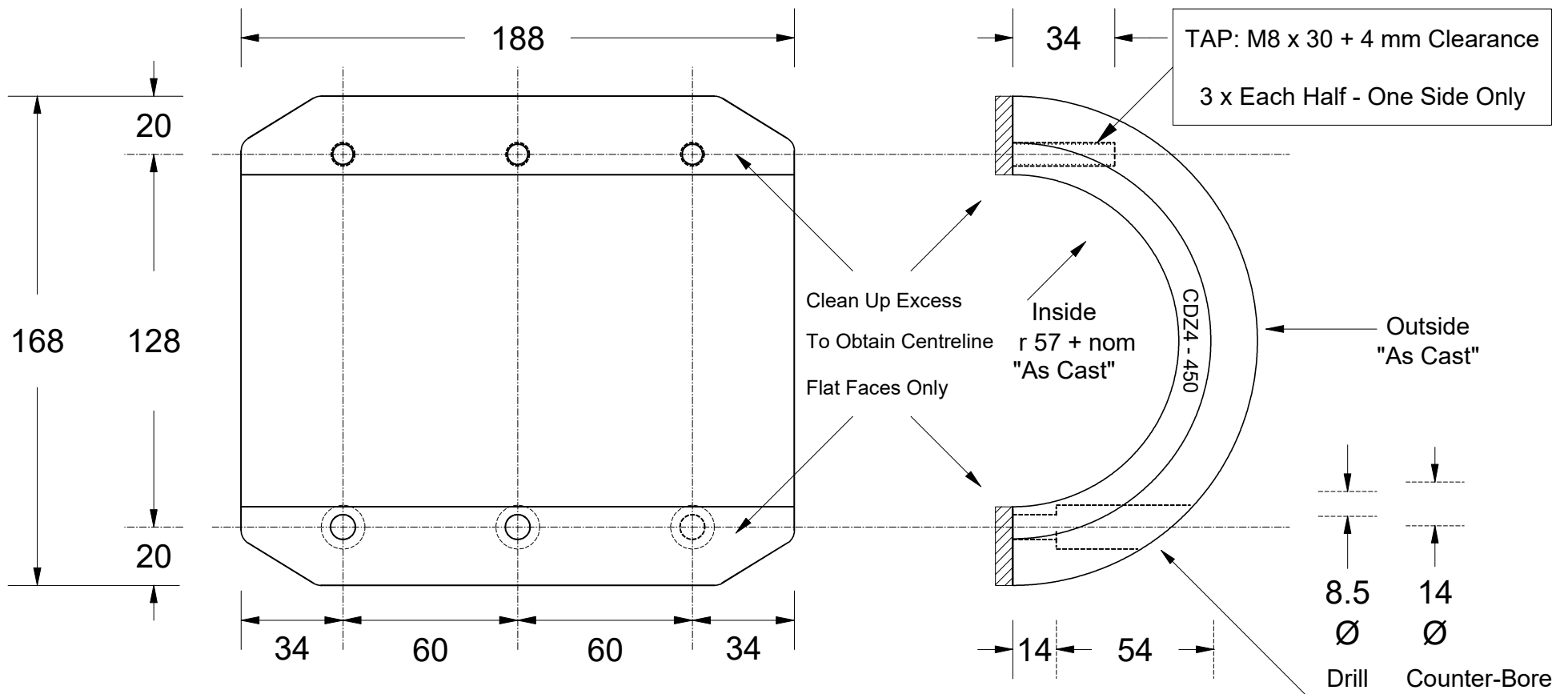

Inside Radius (Diameter) to be left "As Cast" - Outside also "As Cast"

- Notes
1. Anodes are cast to comply with CAA's standard casting tolerances
 2. All sharp edges removed for safe handling
 3. Anode insert material to meet relevant Australian/International specifications



Chemical Composition Limits		Alloy:
Standard: AS2239* (Most current revision)		Z1
Zinc		
Element	min.	max.
Cadmium	0.025	0.07
Aluminium	0.10	0.50
Silicon	-	0.005
Copper	-	0.005
Iron	-	0.005
Lead	-	0.006
Other Impurities		
- each	-	0.005
- total	-	0.02
Zinc	remainder	

* Corresponds to MIL-DTL-18001L alloy composition

Rev	Details of Change(s)	Date	Drawn	Verified
1	Cathodic Diecasting Original	11 September 2011	R.N.	R.G.
2	2013 Catalogue Version (CAA Logo)	15 January 2016	R.N.	R.G.

CAA
Cathodic Anodes Australasia
cathodicanodes.com.au

Product		Zinc Anode - Shaft Anode	
Part no.	CDZ4 - 450	Scale	1 : 2
Drawing No:	CD3196	Rev	2
Drawn by: R Northey		Date: 15 JAN 2016	Sheet 2 of 2

All dimensions are in mm (nominal)