

This drawing is the property of Cathodic Anodes Australasia. To be used with permission only. This drawing becomes an uncontrolled document once issued as hard or electronic copy. Customer to confirm current revision of drawing prior to ordering.

4 x M5 x 16mm 304 S/S Socket Head Cap Screws

4 x M5 304 S/S Internal Tooth Washers

TAP - 4 x M5

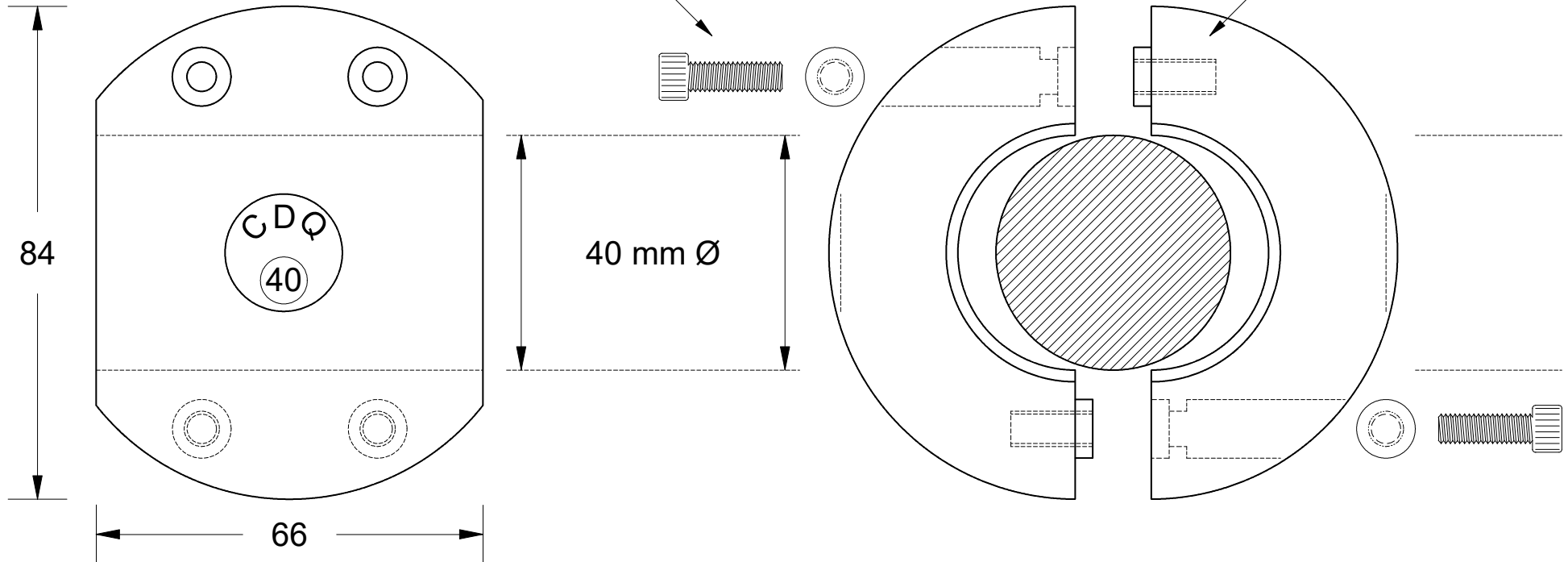

**Intended Use For 40 mm METRIC Shafts**

Chemical Composition Limits		Alloy:
Standard: AS2239* (Most current revision)		<b>Z1</b>
Zinc		
Element	min.	max.
Cadmium	0.025	0.07
Aluminium	0.10	0.50
Silicon	-	0.005
Copper	-	0.005
Iron	-	0.005
Lead	-	0.006
Other Impurities		
- each	-	0.005
- total	-	0.02
Zinc	remainder	

\* Corresponds to MIL-DTL-18001L alloy composition

Notes

1. Anodes are cast to comply with CAA's standard casting tolerances
2. All sharp edges removed for safe handling
3. Anode insert material to meet relevant Australian/International specifications



All dimensions are in mm (nominal)

Rev	Details of Change(s)	Date	Nett Weight		Gross Weight	
			Kg (nominal)		Kg (nominal)	
			<b>1.25</b>		<b>1.30</b>	
1	Cathodic Diecasting Original	05 September 2011		R.N.		R.G.
2	2013 Catalogue Version (CAA Logo)	18 December 2015		R.N.		R.G.



Cathodic Anodes Australasia

[cathodicanodes.com.au](http://cathodicanodes.com.au)

Product		<b>Zinc Anode - Shaft Anode</b>	
Part no.	<b>CDZ4 - 40M</b>	Scale	<b>1 : 1</b>
Drawing No:	<b>CD3170</b>	Rev	<b>2</b>
Drawn by: R Northey	Date: 18 DEC 2015	Sheet	<b>1 of 1</b>

