

This drawing is the property of Cathodic Anodes Australasia. To be used with permission only.
 This drawing becomes an uncontrolled document once issued as hard or electronic copy.
 Customer to confirm current revision of drawing prior to ordering.

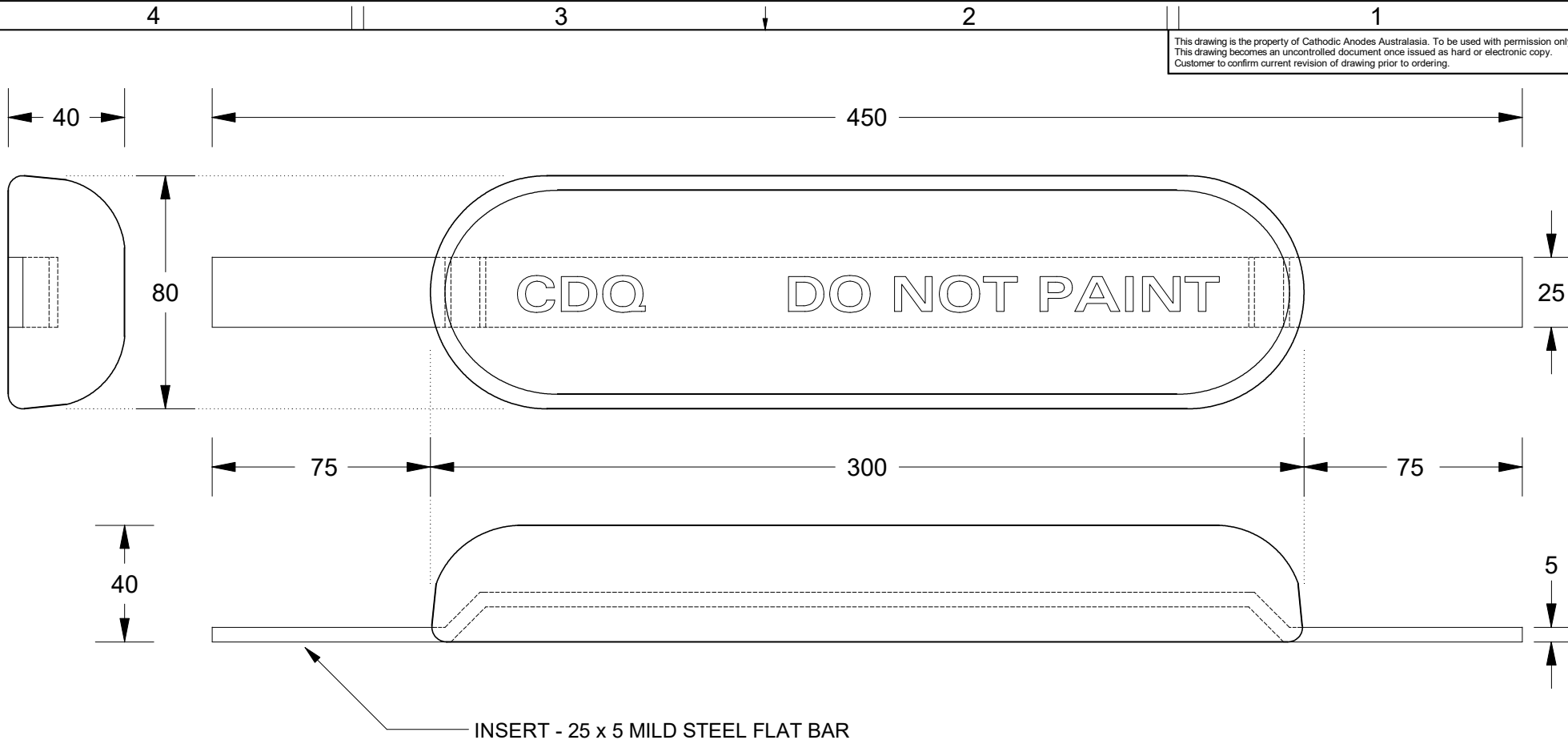

CDQ
 CAST INDENTATION LETTERING

Chemical Composition Limits			Alloy:
Standard: AS2239 (Most current revision)			A1
Aluminium			
Element	min.	max.	
Zinc	2.1	2.7	
Indium	0.017	0.025	
Cadmium	0.008	0.012	
Silicon	-	0.20	
Iron	-	0.12	
Copper	-	0.006	
Other Impurities			
- each	-	0.02	
- total	-	0.05	
Aluminium	remainder		

Notes

1. Anodes are cast to comply with CAA's standard casting tolerances
2. All sharp edges removed for safe handling
3. Anode insert material to meet relevant Australian/International specifications



Rev	Details of Change(s)	Date	Nett Weight		Gross Weight	
			Kg (nominal)		Kg (nominal)	
			1.90		2.30	
1	Cathodic Diecasting Original	21 January 2009		<i>B.L.</i>		<i>R.G.</i>
2	2013 Catalogue Version (CAA Logo)	10 January 2014		<i>R.N.</i>		<i>R.G.</i>

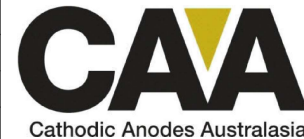

cathodicanodes.com.au

Product		Aluminium Anode	
Part no.	CDA-2S (A1)	Scale	1 : 2
Drawing No:	CD3130	Rev	2
Drawn by: R Northey	Date: 10 JAN 2014	Sheet	1 of 1
Mould No: 92	Strap Sample: 35		

All dimensions are in mm (nominal)