

This drawing is the property of Cathodic Anodes Australasia. To be used with permission only. This drawing becomes an uncontrolled document once issued as hard or electronic copy. Customer to confirm current revision of drawing prior to ordering.

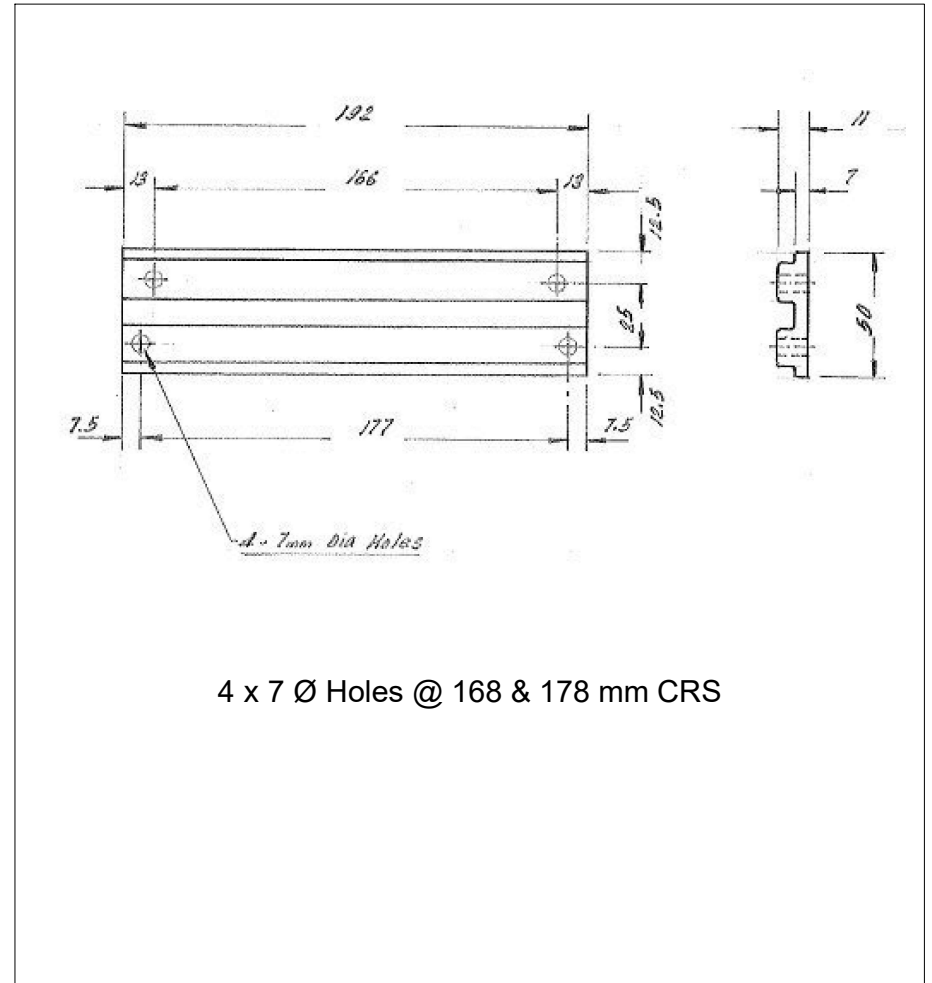

Outboard Plate Anode

Replaces Genuine Part: 818298



4 x 7 Ø Holes @ 168 & 178 mm CRS

All dimensions are in mm (nominal)

Notes

1. Anodes are cast to comply with CAA's standard casting tolerances
2. All sharp edges removed for safe handling
3. Anode insert material to meet relevant Australian/International specifications

Rev	Details of Change(s)	Date	Drawn	Verified
1	Cathodic Diecasting Original	16 Aug 2011	R.N.	R.G.
2	2013 / 2019 Catalogue Version (CAA Logo)	21 Aug 2020	R.N.	R.G.

Chemical Composition Limits		Alloy:
Standard: MIL-DTL-24779A(SH)		24779A
Element	min. max.	
Aluminium (Most current revision)		
Zinc	4.0 6.5	
Indium	0.014 0.020	
Mercury	- 0.001	
Silicon	0.08 0.20	
Iron	- 0.090	
Copper	- 0.004	
Tin	- 0.001	
Aluminium	remainder	

Nett Weight Kg (nominal)	Gross Weight Kg (nominal)
0.230	0.230

CAA
Cathodic Anodes Australasia
cathodicanodes.com.au

Product	
Aluminium Anode	
Part no.	Scale
CDA9-058	NTS
Drawing No: CD3113	Rev Sheet
	2 1 of 1
Drawn by: R Northey Date: 21 AUG 2020	
Mould No: X Tooling:	