

This drawing is the property of Cathodic Anodes Australasia. To be used with permission only.
 This drawing becomes an uncontrolled document once issued as hard or electronic copy.
 Customer to confirm current revision of drawing prior to ordering.

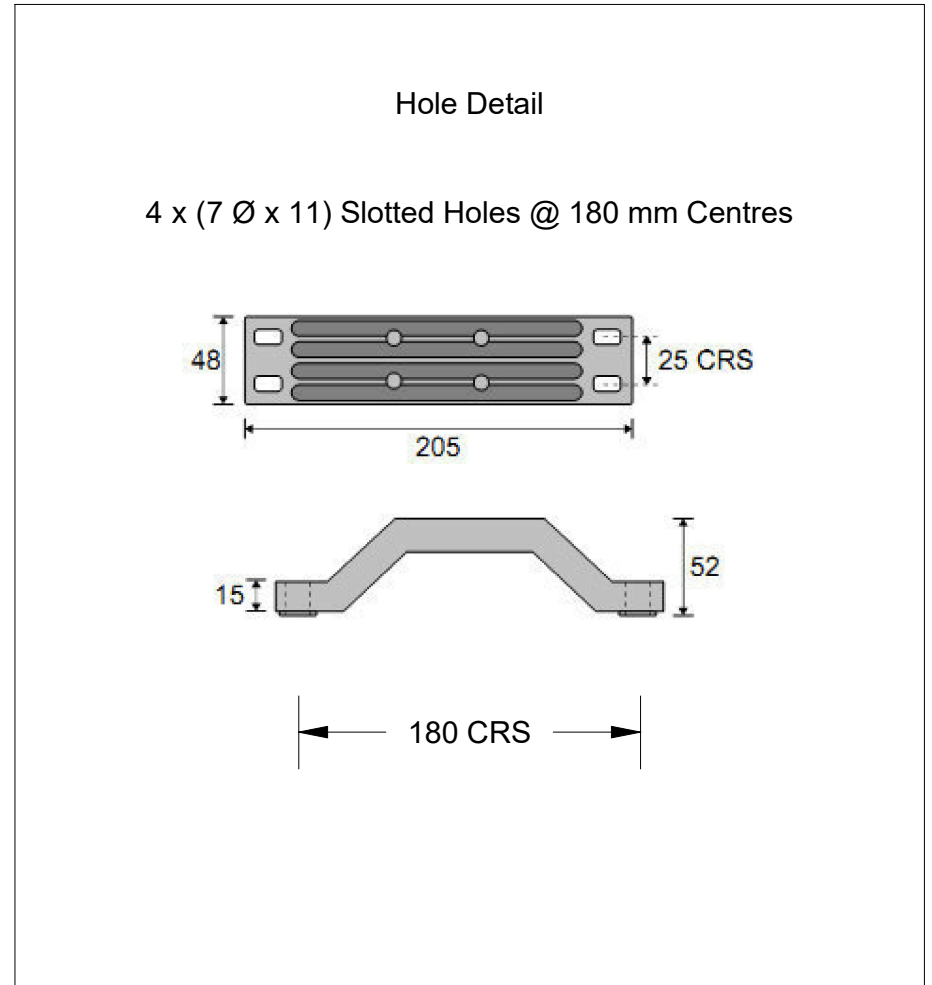

Bracket Anode To Suit 150,200,250 & 300 HP Outboards

Replaces Genuine Part: 6G5-45251-01



All dimensions are in mm (nominal)

Notes

1. Anodes are cast to comply with CAA's standard casting tolerances
2. All sharp edges removed for safe handling
3. Anode insert material to meet relevant Australian/International specifications

Chemical Composition Limits			Alloy: 24779A
Element	min.	max.	
Standard: MIL-DTL-24779A(SH)			
Aluminium	(Most current revision)		
Zinc	4.0	6.5	
Indium	0.014	0.020	
Mercury	-	0.001	
Silicon	0.08	0.20	
Iron	-	0.090	
Copper	-	0.004	
Tin	-	0.001	
Aluminium	remainder		

Rev	Details of Change(s)	Date	Drawn	Verified
1	Cathodic Diecasting Original	15 Aug 2011	R.N.	R.G.
2	2013 / 2019 Catalogue Version (CAA Logo)	21 Aug 2020	R.N.	R.G.

Nett Weight Kg (nominal)	Gross Weight Kg (nominal)
0.340	0.340

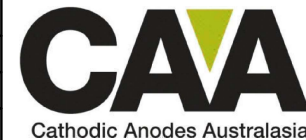

cathodicanodes.com.au

Product Aluminium Anode			
Part no. CDA9-047		Scale NTS	
Drawing No: CD3107		Rev 2	Sheet 1 of 1
Drawn by: R Northey		Date: 21 AUG 2020	
Mould No: X		Tooling:	