

This drawing is the property of Cathodic Anodes Australasia. To be used with permission only.
 This drawing becomes an uncontrolled document once issued as hard or electronic copy.
 Customer to confirm current revision of drawing prior to ordering.

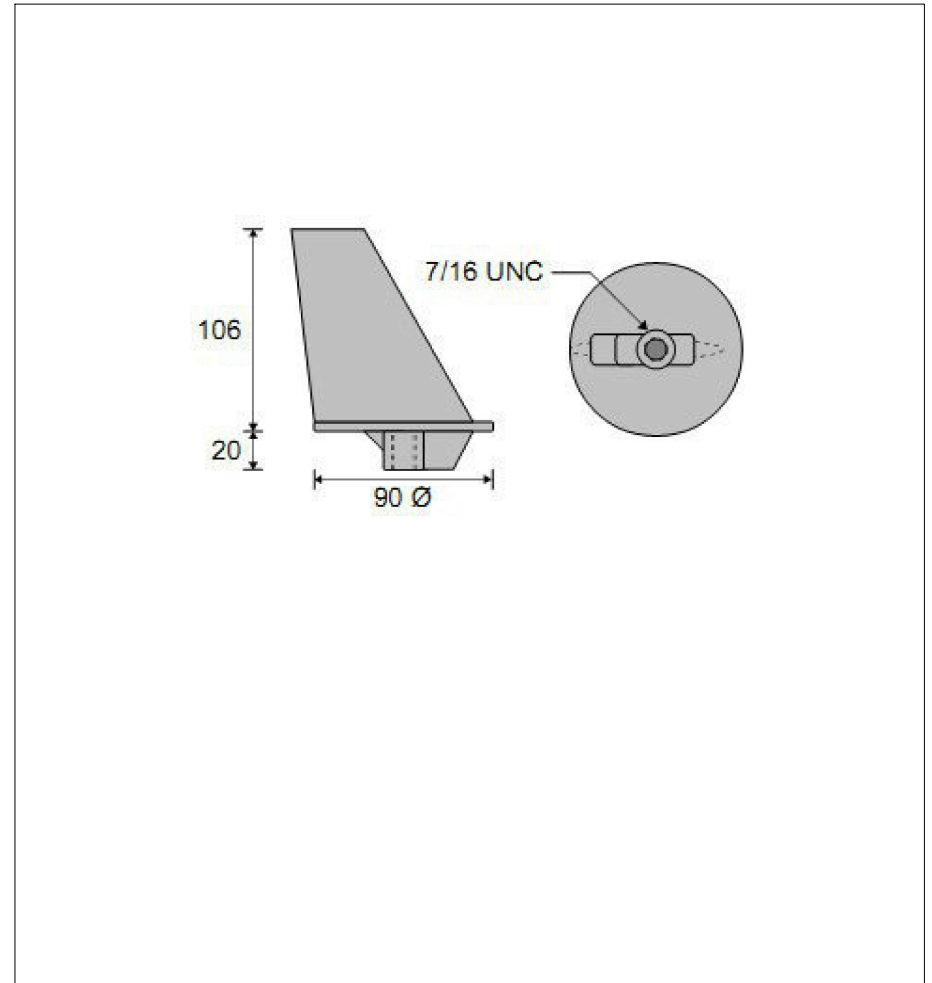

Trim Tab Aluminium Anode - Long Leg

Replaces Genuine Part: 34127



All dimensions are in mm (nominal)

Notes

1. Anodes are cast to comply with CAA's standard casting tolerances
2. All sharp edges removed for safe handling
3. Anode insert material to meet relevant Australian/International specifications

| Chemical Composition Limits | | | Alloy: 24779A |
|---|-----------|-------|-------------------------|
| Standard: MIL-DTL-24779A(SH) Aluminium (Most current revision) | | | |
| Element | min. | max. | |
| Zinc | 4.0 | 6.5 | |
| Indium | 0.014 | 0.020 | |
| Mercury | - | 0.001 | |
| Silicon | 0.08 | 0.20 | |
| Iron | - | 0.090 | |
| Copper | - | 0.004 | |
| Tin | - | 0.001 | |
| Aluminium | remainder | | |

| Rev | Details of Change(s) | Date | Nett Weight Kg (nominal) | | Gross Weight Kg (nominal) | |
|-----|--|-------------|-----------------------------|-------|------------------------------|----------|
| | | | 0.230 | 0.230 | Drawn | Verified |
| 1 | Cathodic Diecasting Original | 12 Aug 2011 | R.N. | R.G. | | |
| 2 | 2013 / 2019 Catalogue Version (CAA Logo) | 21 Aug 2020 | R.N. | R.G. | | |
| | | | | | | |
| | | | | | | |

Cathodic Anodes Australasia

cathodicanodes.com.au

| | | | |
|--|----------|---|------------------------|
| Product Aluminium Anode | | | |
| Part no. CDA9-020 | | Scale NTS | |
| Drawing No: CD3101 | | Rev 2 | Sheet 1 of 1 |
| Drawn by: R Northey Date: 21 AUG 2020 | |  | |
| Mould No: X | Tooling: | | |