

This drawing is the property of Cathodic Anodes Australasia. To be used with permission only.
 This drawing becomes an uncontrolled document once issued as hard or electronic copy.
 Customer to confirm current revision of drawing prior to ordering.

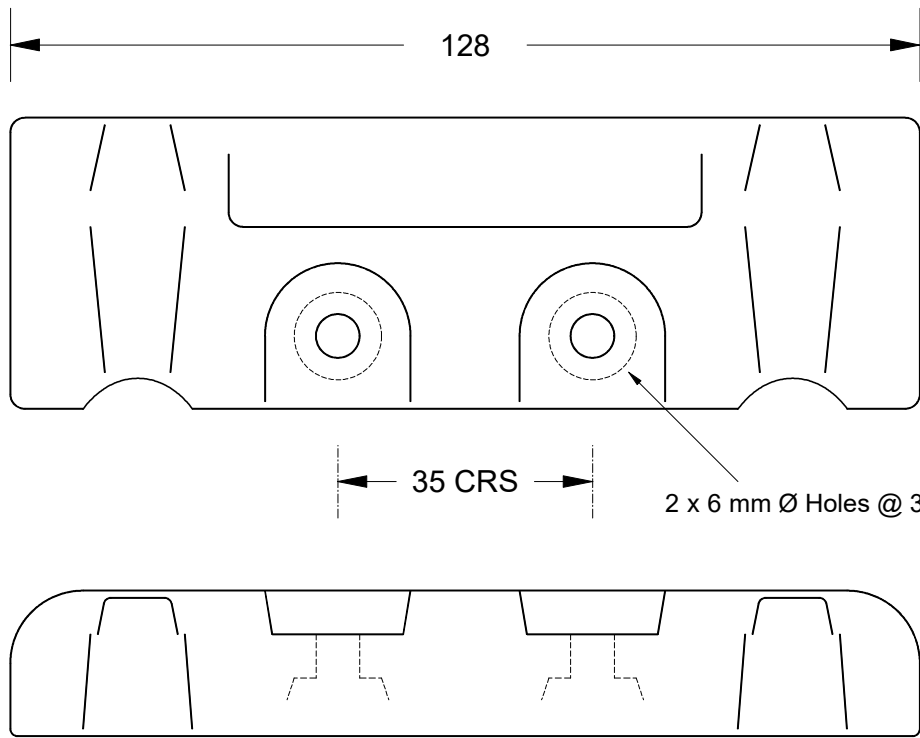
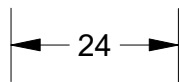
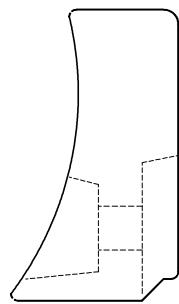

Notes

1. Anodes are cast to comply with CAA's standard casting tolerances
2. All sharp edges removed for safe handling
3. Anode insert material to meet relevant Australian/International specifications

All dimensions are in mm (nominal)

Chemical Composition Limits			Alloy: 24779A
Standard: MIL-DTL-24779A(SH) Aluminium (Most current revision)			
Element	min.	max.	
Zinc	4.0	6.5	
Indium	0.014	0.020	
Mercury	-	0.001	
Silicon	0.08	0.20	
Iron	-	0.090	
Copper	-	0.004	
Tin	-	0.001	
Aluminium	remainder		

Rev	Details of Change(s)	Date	Drawn	Verified
1	New Component - October 2018	21 October 2018	R.N.	R.G.

Nett Weight Kg (nominal)	Gross Weight Kg (nominal)
0.195	0.195

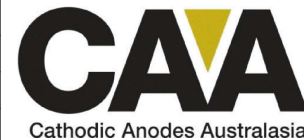

Cathodic Anodes Australasia

cathodicanodes.com.au

Product Aluminium Anode	
Part no. CDA9-203	Scale 1 : 1
Drawing No: CD2470	Rev 1 Sheet 1 of 1
Drawn by: R Northey Date: 21 OCT 2018	