

COMBINATION SET - Individual Components Shown At Top - Plug Material: DEZINCIFICATION RESISTANT BRASS

This drawing is the property of Cathodic Anodes Australasia. To be used with permission only. This drawing becomes an uncontrolled document once issued as hard or electronic copy. Customer to confirm current revision of drawing prior to ordering.

Zinc Anode Only - CAA Part No: CDZ9-004 (Drawing No: CDQ-101)

D.R. Brass Plug 09 (BP09)

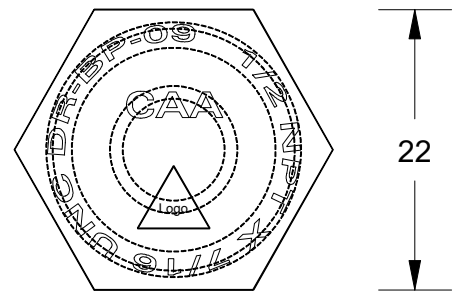
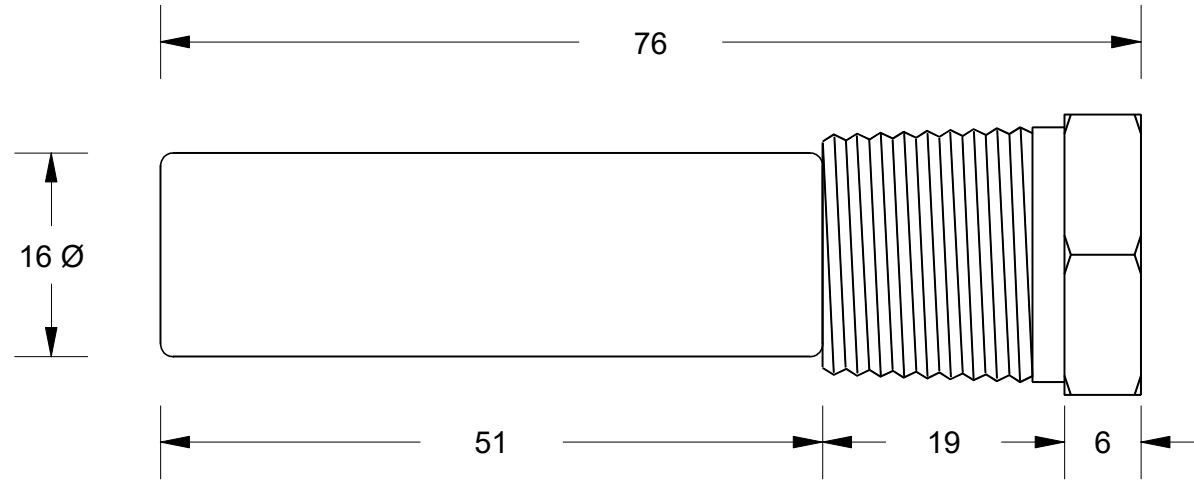
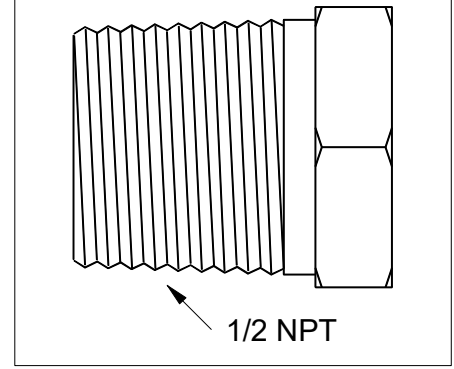
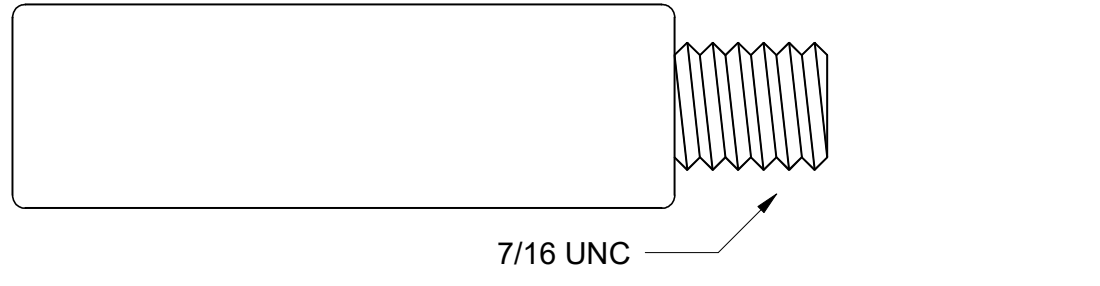

NO SHARP EDGES

= Australian Made Logo

All dimensions are in mm (nominal)

Chemical Composition Limits		Alloy:	
Standard: AS2239* (Most current revision)		<b>Z1</b>	
Element	min.	max.	
Cadmium	0.025	0.07	
Aluminium	0.10	0.50	
Silicon	-	0.005	
Copper	-	0.005	
Iron	-	0.005	
Lead	-	0.006	
Other Impurities			
- each	-	0.005	
- total	-	0.02	
Zinc	remainder		

- Notes
1. Anodes are cast to comply with CAA's standard casting tolerances
  2. All sharp edges removed for safe handling
  3. Anode insert material to meet relevant Australian/International specifications



Rev	Details of Change(s)	Date	Drawn	Verified
1	2018 Catalogue Version	16 FEB 2018	R.N.	R.G.
2	Stamping & Logo added to DR Brass Plug	10 Nov 2020	R.N.	R.G.

Nett Weight Kg (nominal)	Gross Weight Kg (nominal)
<b>0.070</b>	<b>0.130</b>

**CAA**  
Cathodic Anodes Australasia  
cathodicanodes.com.au

Product <b>Zinc Anode &amp; DR Brass Plug</b>	
Part no. <b>CDZ9-199</b>	Scale <b>1.75 : 1</b>
Drawing No: <b>CD2444</b>	Rev <b>2</b> Sheet <b>1 of 1</b>
Drawn by: R Northey Date: 10 NOV 2020	

\* Corresponds to MIL-DTL-18001L alloy composition