

This drawing is the property of Cathodic Anodes Australasia. To be used with permission only.
 This drawing becomes an uncontrolled document once issued as hard or electronic copy.
 Customer to confirm current revision of drawing prior to ordering.

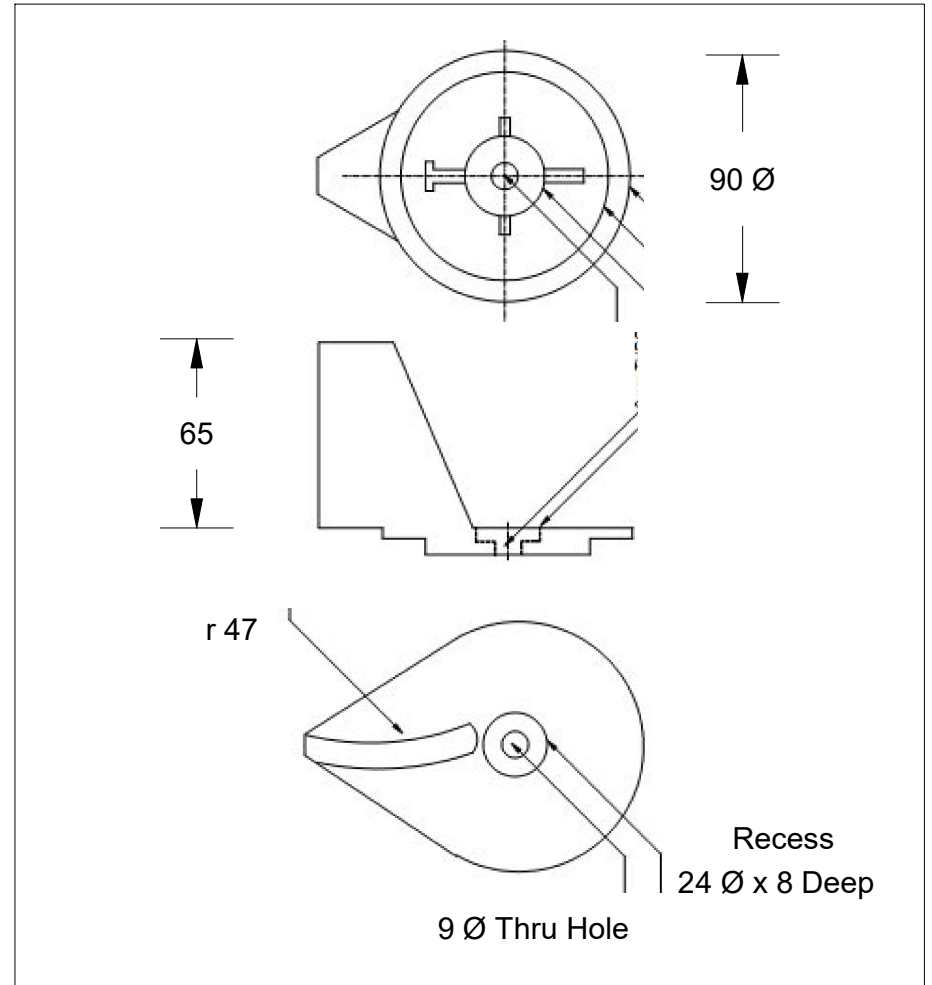

Outboard Trim Tab Anode
 Replaces Genuine Part: 822157

All dimensions are in mm (nominal)

Chemical Composition Limits			Alloy: Z1
Standard: AS2239* (Most current revision)			
Zinc			
Element	min.	max.	
Cadmium	0.025	0.07	
Aluminium	0.10	0.50	
Silicon	-	0.005	
Copper	-	0.005	
Iron	-	0.005	
Lead	-	0.006	
Other Impurities			
- each	-	0.005	
- total	-	0.02	
Zinc	remainder		

* Corresponds to MIL-DTL-18001L alloy composition

Notes

1. Anodes are cast to comply with CAA's standard casting tolerances
2. All sharp edges removed for safe handling
3. Anode insert material to meet relevant Australian/International specifications

Rev	Details of Change(s)	Date	Drawn	Verified
1	Cathodic Diecasting Original	09 Jun 2011	R.N.	R.G.
2	2013 / 2019 Catalogue Version (CAA Logo)	20 Aug 2020	R.N.	R.G.

Nett Weight Kg (nominal)	Gross Weight Kg (nominal)
0.460	0.460

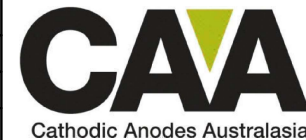

cathodicanodes.com.au

Product Zinc Anode		Scale NTS	
Part no. CDZ9-091		Rev 2	Sheet 1 of 1
Drawing No: CD2144		Date: 20 AUG 2020	
Drawn by: R Northey		Tooling:	
Mould No: X			