

This drawing is the property of Cathodic Anodes Australasia. To be used with permission only.
 This drawing becomes an uncontrolled document once issued as hard or electronic copy.
 Customer to confirm current revision of drawing prior to ordering.

NO SHARP EDGES

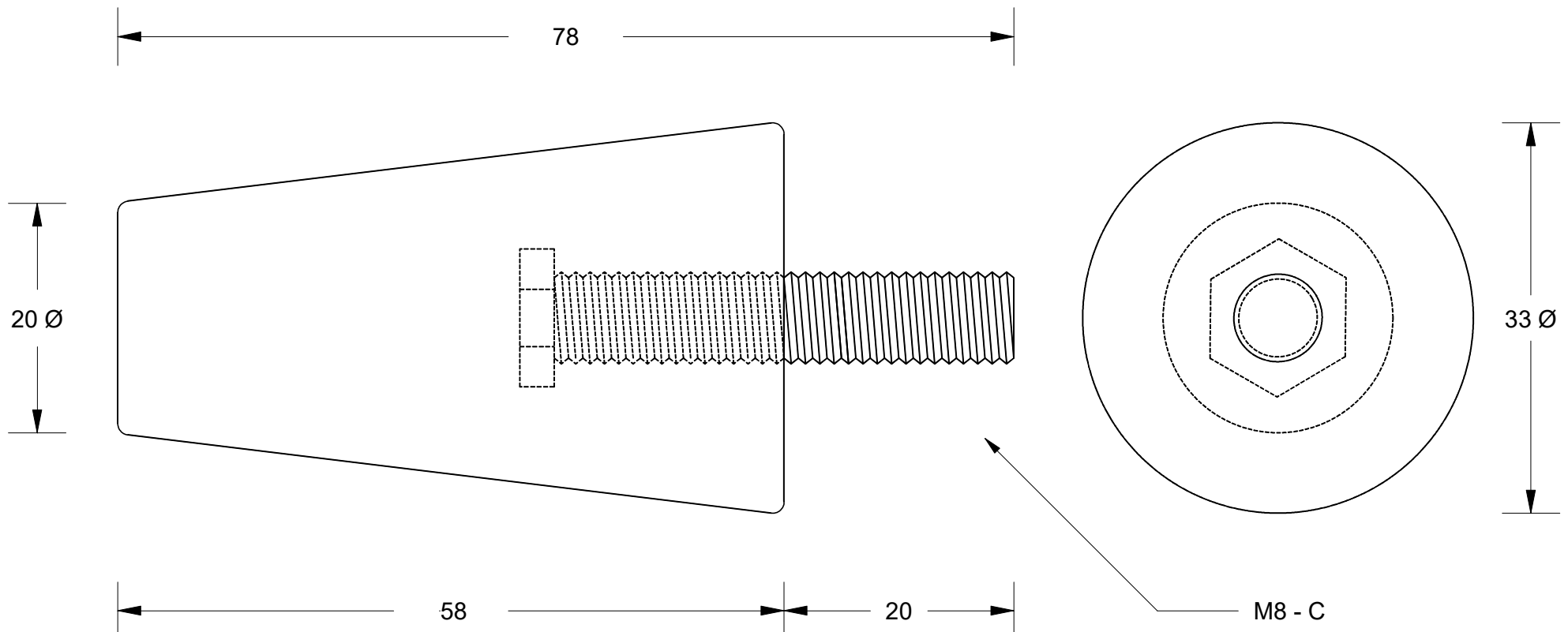

Insert - M8-C (Zinc Plate Hex Set Screw)

Chemical Composition Limits		Alloy:
Standard: AS2239* (Most current revision)		Z1
Zinc		
Element	min.	max.
Cadmium	0.025	0.07
Aluminium	0.10	0.50
Silicon	-	0.005
Copper	-	0.005
Iron	-	0.005
Lead	-	0.006
Other Impurities		
- each	-	0.005
- total	-	0.02
Zinc	remainder	

* Corresponds to MIL-DTL-18001L alloy composition

- Notes
1. Anodes are cast to comply with CAA's standard casting tolerances
 2. All sharp edges removed for safe handling
 3. Anode insert material to meet relevant Australian/International specifications

All dimensions are in mm (nominal)

Rev	Details of Change(s)	Date	Drawn	Verified
1	Cathodic Diecasting Original	09 June 2011	R.N.	R.G.
2	2013 Catalogue Version (CAA Logo)	20 March 2015	R.N.	R.G.

Nett Weight Kg (nominal)	Gross Weight Kg (nominal)
0.220	0.230

CAA
Cathodic Anodes Australasia
cathodicanodes.com.au

Product Zinc Anode	
Part no. CDZ9-089	Scale 2 : 1
Drawing No: CD2133	Rev 2 Sheet 1 of 1
Drawn by: R Northey	Date: 20 MAR 2015