

This drawing is the property of Cathodic Anodes Australasia. To be used with permission only.
 This drawing becomes an uncontrolled document once issued as hard or electronic copy.
 Customer to confirm current revision of drawing prior to ordering.

NO SHARP EDGES

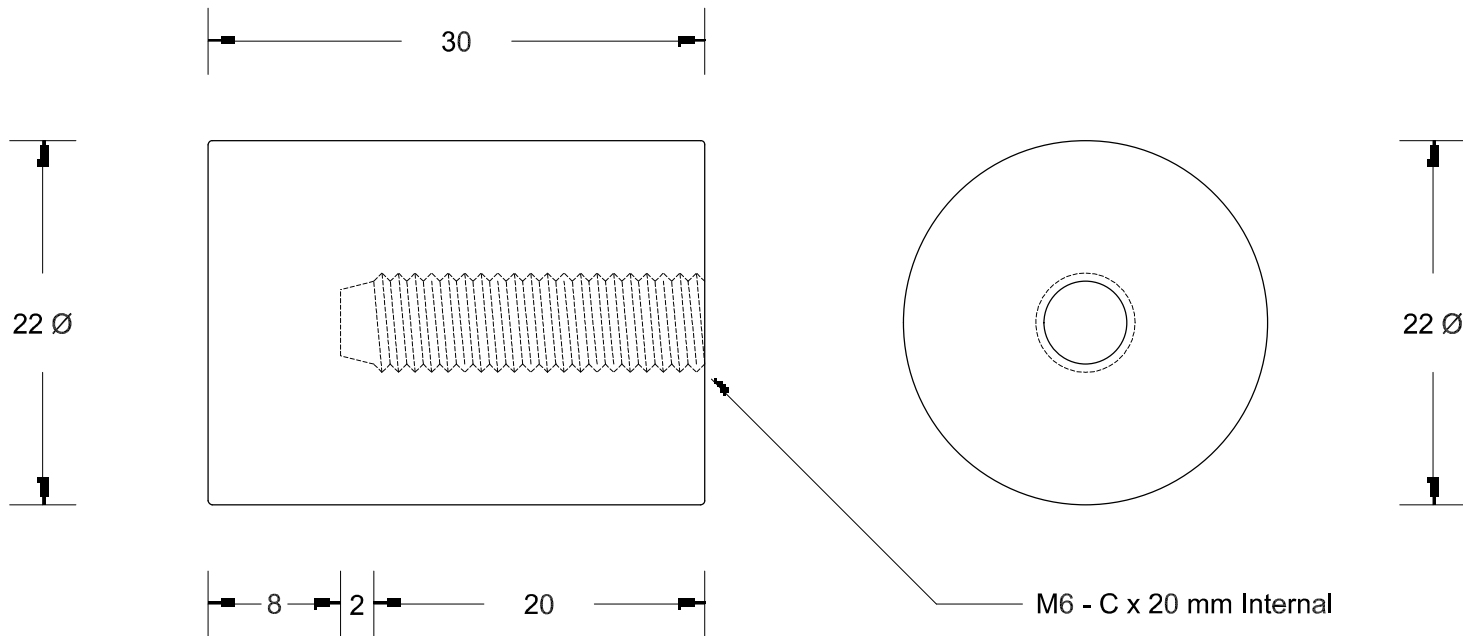

Chemical Composition Limits		Alloy:
Standard: AS2239* (Most current revision)		Z1
Element	min.	max.
Cadmium	0.025	0.07
Aluminium	0.10	0.50
Silicon	-	0.005
Copper	-	0.005
Iron	-	0.005
Lead	-	0.006
Other Impurities	-	-
- each	-	0.005
- total	-	0.02
Zinc	remainder	

* Corresponds to MIL-DTL-18001L alloy composition

Notes

- Anodes are cast to comply with CAA's standard casting tolerances
- All sharp edges removed for safe handling
- Anode insert material to meet relevant Australian/International specifications



Rev	Details of Change(s)	Date	Drawn	Verified
1	Cathodic Diecasting Original	15 Sept 2009	B.L.	R.G.
2	2013 Catalogue Version (CAA Logo)	25 March 2015	R.N.	R.G.

Nett Weight Kg (nominal)	Gross Weight Kg (nominal)
0.070	0.070

CAA
 Cathodic Anodes Australasia
 cathodicanodes.com.au

Product Zinc Anode		All dimensions are in mm (nominal)	
Part no. CDZ9-140	Scale 2.5 : 1	Rev 2	Sheet 1 of 1
Drawing No: CD1270			
Drawn by: R Northey Date: 25 MAR 2015			